

Operation Management

MBA – 2ND SEM

**HI-TECH INSTITUTE OF TECHNOLOGY
INDUSTRIAL ESTATE, KHURDA**

Index

I. Content.....	II
II. List of Figures	VI
III. List of Tables.....	VII
IV. Abbreviations	VIII
V. Case Study.....	113
VI. Bibliography	117
VII. Self Assessment Answers	120
Book at a Glance	

Contents

Chapter I.....	1
Operation Management Concepts.....	1
Aim.....	1
Objectives.....	1
Learning outcome.....	1
Introduction.....	2
Operations System.....	2
A Framework of Managing Operations.....	2
Operations Management.....	4
Transformation and Value Adding Activities.....	5
Operations Management Objectives.....	5
Scope of Operations Management.....	6
Summary.....	10
References.....	10
Recommended Reading.....	10
Self Assessment.....	11
Chapter II.....	13
Production Processes, Manufacturing and Service Operations.....	13
Aim.....	13
Objectives.....	13
Learning outcome.....	13
Introduction.....	14
Production Processes.....	14
Manufacturing Operations and Service Operations.....	14
Characteristics of Manufacturing.....	16
Characteristics of Services.....	17
Challenges faced by Operations Managers.....	18
Summary.....	20
References.....	20
Recommended Reading.....	20
Self Assessment.....	21
Chapter III.....	23
Production, Planning and Control.....	23
Aim.....	23
Objectives.....	23
Learning outcome.....	23
Introduction.....	24
Objectives of Production Planning and Control.....	25
Scope of Production Planning and Control.....	25
Principles of Production Planning and Control.....	26
Functions of Production Planning and Control.....	26
Benefits of Production Planning and Control Function.....	28
Limitations of Production Planning and Control Function.....	29
Production Planning and Control in Different Production System.....	29
Factors Affecting the Choice of Manufacturing Process.....	30
Summary.....	31
References.....	31
Recommended Reading.....	31
Self Assessment.....	32

Chapter IV	34
Long Range Capacity Planning and Facility Location	34
Aim.....	34
Objectives	34
Learning outcome	34
Introduction.....	35
Long Range Capacity Planning.....	36
Estimating the Capacities of Existing Facilities	36
Forecasting Long-term Future Capacity Demand	38
Identifying and Analysing Sources of Capacity to Meet Future Capacity Needs.....	39
Capacity Management	39
Selecting from among the Alternative Sources of Capacity.....	40
Facility Location	43
Steps in Location Selection.....	43
Domestic or International Location.....	43
Selection of region	43
Selection of community.....	45
Selection of Site	46
Errors in Selection	46
Importance of Location Factors.....	47
Location Models.....	48
Summary	49
References	49
Recommended Reading	49
Self Assessment	50
Chapter V	52
Facility Layout	52
Aim.....	52
Objectives	52
Learning outcome	52
Introduction to Facility Layout	53
Inputs of the Layout.....	53
Types of Layout.....	53
Process Layout/ Job Shop Layout	53
Product Layout/ Flow Shop Layout	54
Group Technology Layout.....	55
Fixed Position Layout	56
Flexible Manufacturing System	57
Layout Design Procedure.....	57
Layout Problem.....	57
Importance of Facility Layout.....	60
Summary	61
References	61
Recommended Reading	61
Self Assessment	62
Chapter VI	64
Work System Design	64
Aim.....	64
Objectives	64
Learning outcome	64
Introduction.....	65
Design of Work System	65
Different Terminologies in Work Design System	65

Job Design	66
Factors that Affect Job Design	66
Design of Work Systems	66
Specialisation	66
Behavioral Approaches to Job Design	66
Motivation	66
Teams	67
Methods Analysis	67
Motion Study	68
Motion Study Principles	68
Analysis of Therbligs	68
Working Conditions	69
Characteristics of Incentive Plan	70
Types of Individual Incentive Plans	70
Summary	71
References	71
Recommended Reading	71
Self Assessment	72
Chapter VII.....	74
Quality Management	74
Aim	74
Objectives.....	74
Learning outcome	74
Introduction	75
Definition of Total Quality Management.....	75
Defining Quality	75
Cost of Quality.....	75
Continuous Improvement (Kaizen).....	77
Plan to Study Cycle.....	77
Benchmarking.....	78
Employee Empowerment	79
Team Approach.....	79
Tools of Quality Control.....	79
Cause-and-Effect Diagrams	80
Flowcharts	80
Checklists	80
Control Charts.....	80
Scatter Diagrams	81
Pareto Analysis	81
Histograms	81
Process Management.....	82
Quality Standards.....	82
ISO 9000 Standards.....	82
ISO 14000 Standards.....	83
Reason for TQM Failure	83
Summary	85
References	85
Recommended Reading	85
Self Assessment	86

Chapter VIII	88
Project Planning and Work Breakdown Structure	88
Aim.....	88
Objectives	88
Learning outcome	88
Introduction.....	89
Project Management Knowledge Areas.....	89
Project Failure	90
Project Planning	90
Scoping 90	
A Typical Outline of the Task.....	91
Tasks Involved in Scoping.....	91
Project Plan	91
Planning Tools	91
Project Process Flow	92
Project Process.....	92
Process Groups	92
Work Breakdown Structure (WBS)	94
Summary	95
References	95
Recommended Reading	95
Self Assessment	96
Chapter IX	98
JIT, Lean Manufacturing, Six-Sigma	98
Aim.....	98
Objectives	98
Learning outcome	98
Introduction.....	99
History and Philosophy of Just-In-Time (JIT)	99
Just-In-Time Concept	99
Benefits and Problems	100
Implementation of JIT	101
Lean Manufacturing	103
Lean Production.....	103
Lean Production Overview	104
Basic Elements of Lean Manufacturing	104
Characteristics of a Lean Enterprise.....	104
Key Feature of Lean Production	105
Benefits of Lean Production	105
Five Elements to Enabling Approach	105
13 Tips to Transition Company into Lean Enterprise.....	106
Six-Sigma.....	106
Objectives of Six-Sigma	106
Integrating Six Sigma with Business Process Management	106
Six Main Benefits of the Sigma Breakthrough Strategy.....	107
Difference between TQM and Six Sigma	107
Critical Success Factors of an Organisation.....	107
Summary	109
References	109
Recommended Reading	110
Self Assessment	111

List of Figures

Fig. 1.1 Operations system for stores department.....	2
Fig. 1.2 General model for managing operations	3
Fig. 1.3 Schematic model for operations/production system.....	5
Fig. 1.4 Environment of operations	7
Fig. 2.1 Examples of tangible and intangible goods/services.....	15
Fig. 3.1 Three stages in PPC.....	24
Fig. 3.2 Functions of production planning and control	26
Fig. 4.1 Determinants of effective capacity.....	38
Fig. 5.1 Job shop layout	54
Fig. 5.2 Flow shop layout.....	55
Fig. 5.3 Group technology layout	56
Fig. 5.4 Fixed position layout.....	56
Fig. 5.5 A layout of departments.....	58
Fig. 5.6 From to matrix for the office example	58
Fig. 5.7 Computation of the total distance travelled	59
Fig. 6.1 Terminologies in work design system	65
Fig. 7.1 Cost of defects	77
Fig. 7.2 PDSA cycle.....	78
Fig. 7.3 Seven tools of quality control	82
Fig. 8.1 Project management knowledge areas.....	89
Fig. 8.2 Connection between process groups in a phase	93
Fig. 8.3 Schematic flow diagram of the processes.....	94
Fig. 9.1 Drawing of the JIT concept	100
Fig. 9.2 Algorithm of JIT implementation.....	103

List of Tables

Table 1.1 Aspects of customer service.....	6
Table 1.2 The objectives of operations management.....	6
Table 2.1 Difference between manufacturing operations and service operations	16
Table 2.2 Characteristics of Manufacturing	17
Table 3.1 Tabular representation of different levels of production planning system.....	28
Table 4.1 Example of capacity measure	35
Table 7.1 Cost of quality.....	76
Table 9.1 Comparison between flexible systems and buffered/rigid systems.....	101

Abbreviations

BOM	-	Bill of Materials
BPR	-	Business Process Re-engineering
CAD	-	Computer Aided Design
CAM	-	Computer Aided Manufacturing
CRM	-	Customer Relationship Management
CRP	-	Capacity Requirement Planning
DFSS	-	Design for Six Sigma
DMAIC	-	Define, Measure, Analyse, Improve, Control
DRP	-	Distribution Requirement Planning
ETM	-	Enterprise Transaction Module
ERP	-	Enterprise Resource Planning
EV	-	Expected Value
FC	-	Fixed Costs
FCS	-	Finite Capacity Scheduling
FMS	-	Flexible Manufacturing System
GDP	-	Gross Domestic Product
ICT	-	Information and Communication Technologies
ISO	-	International Organisation for Standardisation
JIT	-	Just-In-Time
LCL	-	Lower Control Limit
MO	-	Manufacturing Operations
MPS	-	Master Production Schedule
MRP	-	Materials Requirement Planning
MTM	-	Methods Time Measurement
OM	-	Operations Management
OR	-	Operational Research
PDSA	-	Plan Do Study Act
PPC	-	Production Planning Control
QFD	-	Quality Function Deployment
RDB	-	Rational Database
SCM	-	Supply Chain Management
SFC	-	Shop Floor Control
SO	-	Service Operations
TC	-	Total Cost
TPS	-	Toyota Production System
TQM	-	Total Quality Management
UCL	-	Upper Control Limit
VC	-	Variable Cost
WBS	-	Work Breakdown Structure

Chapter I

Operation Management Concepts

Aim

The aim of this chapter is to:

- explain the concept of operation management
- explain the scope of operations management
- explicate transformation and value adding activities

Objectives

The objectives of this chapter are to:

- enlist the objectives of operation management
- explain the customer service objectives
- elucidate activities, which are listed under production and operations management function

Learning outcome

At the end of this chapter, you will be able to:

- understand operation management
- identify the resource utilisation objectives
- describe objectives of operation management

1.1 Introduction

Operation is that part of an organisation, which is concerned with the transformation of a range of inputs into the required output (services) having the requisite quality level. Management is the process, which combines and transforms various resources used in the operations subsystem of the organisation into value added services in a controlled manner as per the policies of the organisation.

The set of interrelated management activities, which are involved in manufacturing certain products, is called as production management. If the same concept is extended to services management, then the corresponding set of management activities is called as operations management.

1.2 Operations System

An operation was defined in terms of the mission it serves for the organisation, technology it employs and the human and managerial processes it involves. Operations in an organisation can be categorised into Manufacturing Operations and Service Operations. Manufacturing Operations is a conversion process that includes manufacturing yields a tangible output: a product, whereas, a conversion process that includes service yields an intangible output: a deed, a performance, an effort.

Operations system converts inputs in order to provide outputs, which are required by a customer. It converts physical resources into outputs, the function of which is to satisfy customer wants. Everett E. Adam & Ronald J. Ebert defines as ‘An operating system is the part of an organisation that produces the organisation’s physical goods and services’. Ray Wild defines operations system as ‘a configuration of resources combined for the provision of goods or services’.

In some of the organisation the product is a physical good (breakfast in hotels) while in others it is a service (treatment in hospitals). Bus and taxi services, tailors, hospital and builders are the examples of an operations system. The basic elements of an operation system show in Fig. 1.3 with reference to departmental stores.

A departmental store’s has an input like land upon which the building is located, labour as a stock clerk, capital in the form of building, equipment and merchandise, management skills in the form of the store’s manager. Output will be serviced customer with desired merchandise. Random fluctuations will be from external or internal sources, monitored through a feedback system

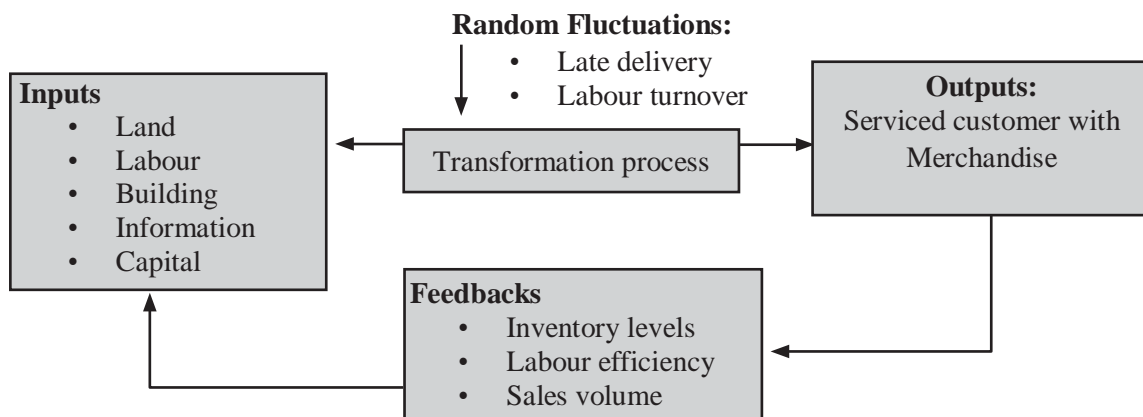

Fig. 1.1 Operations system for stores department
 (Source: http://tn.upi.edu/pdf/Operations_Management.pdf)

1.3 A Framework of Managing Operations

Managing Operations can be enclosed in a frame of general management function as shown in Fig. 1.1. Operation managers are concerned with planning, organising, and controlling the activities, which affect human behaviour through models. Planning is the activity that establishes a course of action and guide future decision-making. The operations manager defines the objectives for the operations subsystem of the organisation, and the policies,

and procedures for achieving the objectives. This stage includes clarifying the role and focus of operations in the organisation's overall strategy. It also involves product planning, facility designing and using the conversion process.

Organising is the activities that establish a structure of tasks and authority. Operation managers establish a structure of roles and the flow of information within the operations subsystem. They determine the activities required to achieve the goals and assign authority and responsibility for carrying them out.

Controlling is the activities that assure the actual performance in accordance with planned performance. To ensure that the plans for the operations subsystems are accomplished, the operations manager must exercise control by measuring actual outputs and comparing them to planned operations management. Controlling costs, quality, and schedules are the important functions here.

- Behaviour: Operations managers are concerned with the activities, which affect human behaviour through models. They want to know the behaviour of subordinates, which affects managerial activities. Their main interest lies in the decision-making behaviour.
- Models: Models represents schematic representation of the situation, which will be used as a tool for decision-making. Following are some of the models used. Aggregate planning models for examining how best to use existing capacity in short term, break-even analysis to identify break-even volumes, Linear programming and computer simulation for capacity utilisation, Decision tree analysis for long-term capacity problem of facility expansion, simple median model for determining best locations of facilities, etc.

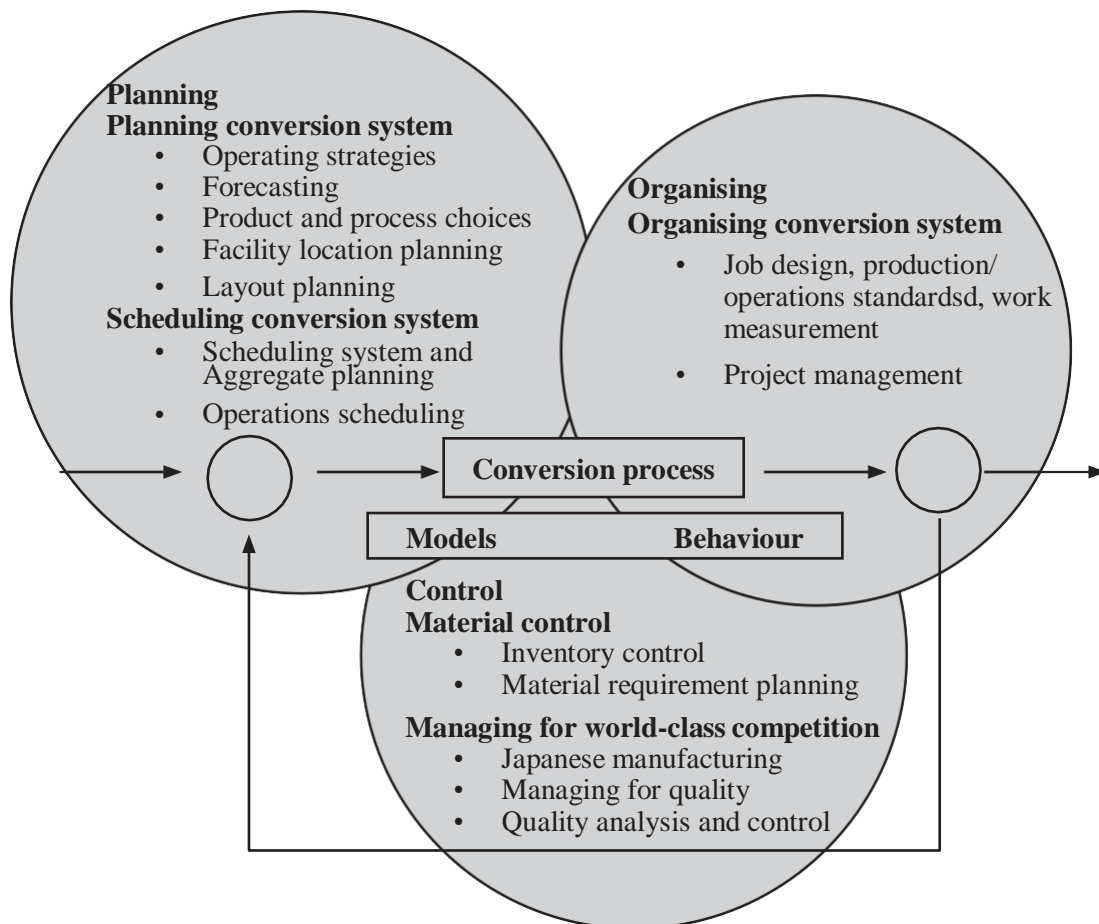

Fig. 1.2 General model for managing operations
 (Source: http://tn.upi.edu/pdf/Operations_Management.pdf)

1.4 Operations Management

Joseph G. Monks defines Operations Management as the process whereby resources, flowing within a defined system, are combined and transformed by a controlled manner to add value in accordance with policies communicated by management.

The operations managers have the prime responsibility for processing inputs into outputs. They must bring together under production plan that effectively uses the materials, capacity and knowledge available in the production facility. Given a demand on the system work must be scheduled and controlled to produce goods and/or services required. Control must be exercised over such parameters such as costs, quality and inventory levels.

The definition of the operations Management contains following keywords: Resources, Systems, transformation and Value addition Activities.

Resources

Resources are the human, material and capital inputs to the production process. Human resources are the key assets of an organisation. As the technology advances, a large proportion of human input is in planning and controlling activities. By using the intellectual capabilities of people, managers can multiply the value of their employees into by many times. Material resources are the physical facilities and materials such as plant equipment, inventories and supplies. These are the major assets of an organisation. Capital in the form of stock, bonds, and/or taxes and contributions is a vital asset. Capital is a store of value, which is used to regulate the flow of the other resources.

Systems

Systems are the arrangement of components designed to achieve objectives according to the plan. The business systems are subsystem of large social systems. In turn, it contains subsystem such as personnel, engineering, finance and operations, which will function for the good of the organisation.

A systems approach to operations management recognises the hierarchical management responsibilities. If subsystems goals are pursued independently, it will result in sub-optimisation. A consistent and integrative approach will lead to optimisation of overall system goals.

The system approach to specific problems requires that the problem first be identified and isolated from the maze of the less relevant data that constitute the environment. The problem abstracted from the overall (macro) environment. Then it can be broken into manageable (micro) parts and analysed and solutions proposed. Doing this analysis is advantageous before making any changes. If the solution appears to solve the problem in a satisfactory way, changes can be made to the real system in an orderly and predictable way.

The ability of any system to achieve its objective depends on its design and its control. System design is a predetermined arrangement of components. It establishes the relationships that must exist between inputs, transformation activities and outputs in order to achieve the system objectives. With the most structured design, there will be less planning and decision-making in the operations of the system. System control consists of all actions necessary to ensure that activities conform to preconceived plans or goals. It involves following four essential elements:

- Measurement by an accurate sensory device.
- Feedback of information in a timely manner.
- Comparison with standards such as time and cost standards.
- Corrective actions by someone with the authority and ability to correct.

A closed loop control system can automatically function on the basis of data from within its own system.

1.5 Transformation and Value Adding Activities

The objective of combining resources under controlled conditions is to transform them into goods and services having a higher value than the original inputs. The transformation process applied will be in the form of technology to the inputs. The effectiveness of the production factors in the transformation process is known as productivity.

The productivity refers to the ratio between values of output per work hour to the cost of inputs. The firms overall ratio must be greater than 1, then we can say value is added to the product. Operations manager should concentrate improving the transformation efficiency and to increase the ratio.

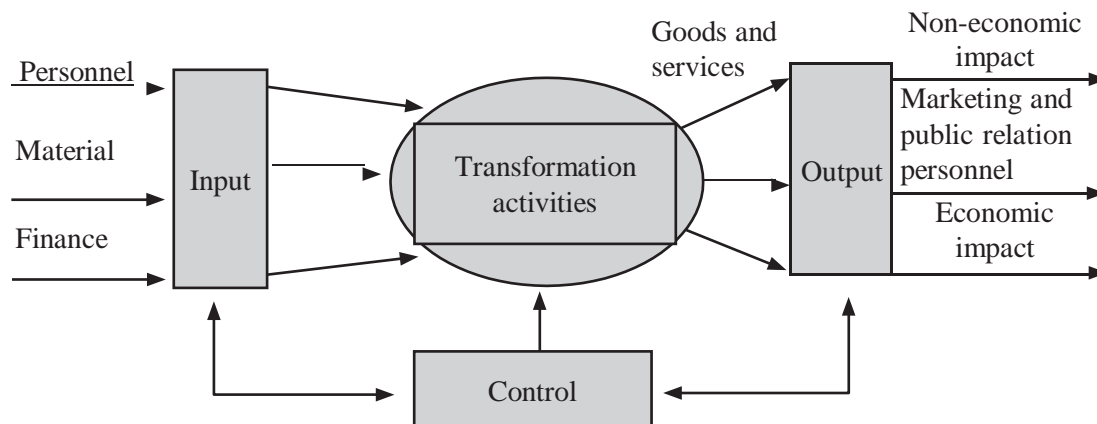

Fig. 1.3 Schematic model for operations/production system
(Source: http://tn.upi.edu/pdf/Operations_Management.pdf)

1.6 Operations Management Objectives

Joseph G. Monks defines Operations Management as the process whereby resources, flowing within a defined system, are combined and transformed by a controlled manner to add value in accordance with policies communicated by management. Objectives of Operations Management can be categorised into customer service and resource utilisation.

Customer service

The first objective of operating systems is to utilise resources for the satisfaction of customer wants. Therefore, customer service is a key objective of operations management. The operating system must provide something to a specification, which can satisfy the customer in terms of cost and timing. Thus, providing the 'right thing at a right price at the right time' can satisfy primary objective. These aspects of customer service – specification, cost and timing – are described for four functions in Table 1.1. They are the principal sources of customer satisfaction and must therefore be the principal dimension of the customer service objective for operations managers.

Generally, an organisation will aim reliably and consistently to achieve certain standards and operations manager will be influential in attempting to achieve these standards. Hence, this objective will influence the operations manager's decisions to achieve the required customer service.

Principal function	Principal customer wants	
	Primary considerations	Other considerations
Manufacture	Goods of a given, requested or acceptable specification	Cost, i.e. purchase price or cost of obtaining goods. Timing, i.e. delivery delay from order or request to receipt of goods
Transport	Management of a given, requested or acceptable specification	Cost, i.e. cost of movements. Timing, i.e. 1. Duration or time to move. 2. Wait or delay from requesting to its commencement.

Supply	Goods of a given, requested or acceptable specification	Cost, i.e. purchase price or cost of obtaining goods. Timing, i.e. delivery delay from order or request to receipt of goods.
Service	Treatment of a given, requested or acceptable specification	Cost, i.e. cost of movements. Timing, i.e. 1. Duration or time required for treatment. 2. Wait or delay from requesting treatment.

Table 1.1 Aspects of customer service

Resource utilisation

Another major objective of operating systems is to utilise resources for the satisfaction of customer wants effectively. Customer service must be provided with the achievement of effective operations through efficient use of resources. Inefficient use of resources or inadequate customer service leads to commercial failure of an operating system.

Operations management is concerned essentially with the utilisation of resources, i.e. obtaining maximum effect from resources or minimising their loss, under utilisation or waste. The extent of the utilisation of the resources’ potential might be expressed in terms of the proportion of available time used or occupied, space utilisation, levels of activity, etc. Each measure indicates the extent to which the potential or capacity of such resources is utilised. This is referred as the objective of resource utilisation.

Operations management is concerned with the achievement of both satisfactory customer service and resource utilisation. An improvement in one will often give rise to deterioration in the other. Often both cannot be maximised, and hence a satisfactory performance must be achieved on both objectives. All the activities of operations management must be tackled with these two objectives in mind, and because of this conflict, operations managers’ will face many of the problems. Hence, operations managers must attempt to balance these basic objectives.

The Table 1.3 summarizes the twin objectives of operations management. The type of balance established both between and within these basic objectives will be influenced by market considerations, competitions, the strengths and weaknesses of the organisation, etc. Hence, the operations managers should make a contribution when these objectives are set.

The customer service objective	The resource utilisations objective
To provide agreed/adequate levels of customer service (and hence customer satisfaction) by providing goods or services with the right specification, at the right cost and the right time	To achieve adequate levels of resource utilisations (or productivity) e.g. to achieve agreed levels of utilisations of materials, machines and labour.

Table 1.2 The objectives of operations management

1.7 Scope of Operations Management

Operations Management concern with the conversion of inputs into outputs, using physical resources, so as to provide the desired utilities to the customer while meeting the other organisational objectives of effectiveness, efficiency and adoptability. It distinguishes itself from other functions such as personnel, marketing, finance, etc. by its primary concern for ‘conversion by using physical resources’.

Following are the activities, which are listed under Production and Operations Management functions:

- Location of facilities.
- Plant layouts and Material Handling.
- Product Design.
- Process Design.

- Production and Planning Control.
- Quality Control.
- Materials Management.
- Maintenance Management

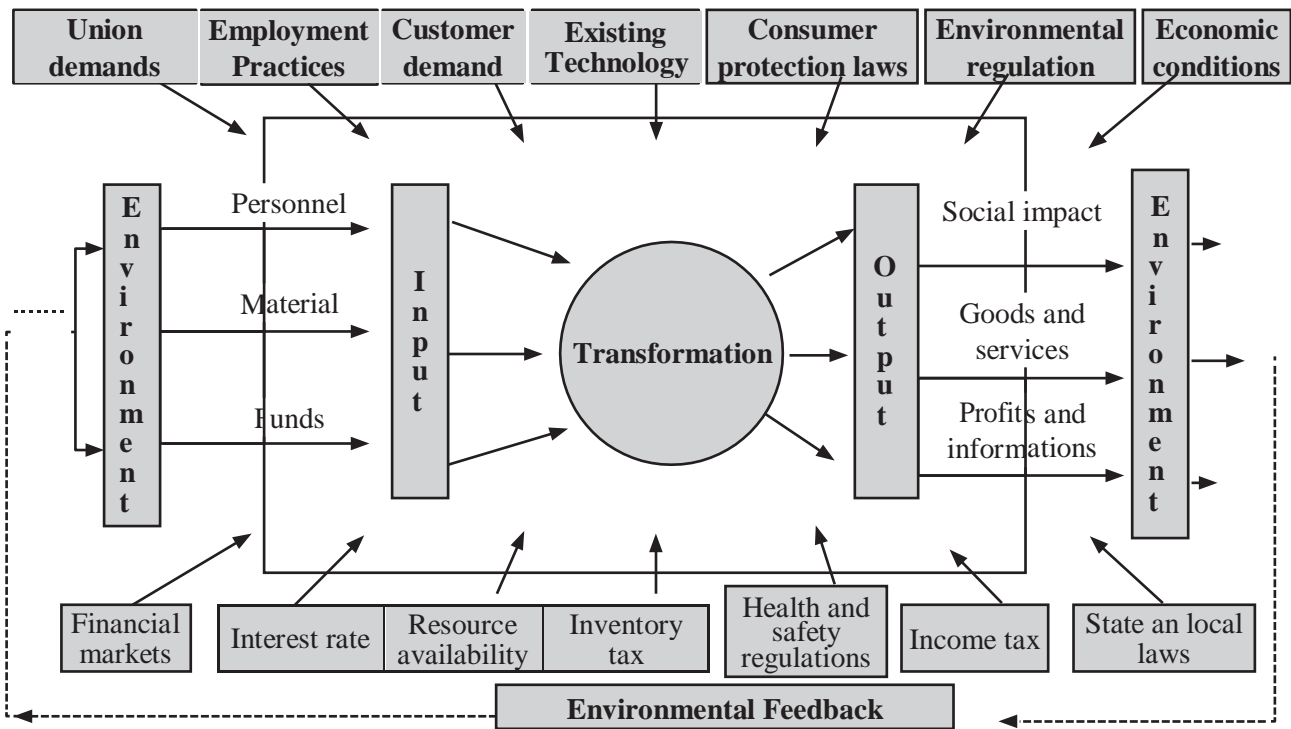

Fig. 1.4 Environment of operations

Location of facilities

Location of facilities for operations is a long-term capacity decision, which involves a long-term commitment about the geographically static factors that affect a business organisation. It is an important strategic level decision-making for an organisation. It deals with the questions such as ‘where our main operations should be based?’

The selection of location is a key-decision as large investment is made in building plant and machinery. An improper location of plant may lead to waste of all the investments made in plant and machinery equipments. Hence, location of plant should be based on the company’s expansion plan and policy, diversification plan for the products, changing sources of raw materials and many other factors. The purpose of the location study is to find the optimal location that will results in the greatest advantage to the organisation.

Plant layout and material handling

Plant layout refers to the physical arrangement of facilities. It is the configuration of departments, work centres and equipment in the conversion process. The overall objective of the plant layout is to design a physical arrangement that meets the required output quality and quantity most economically.

According to James More ‘Plant layout is a plan of an optimum arrangement of facilities including personnel, operating equipment, storage space, material handling equipments and all other supporting services along with the design of best structure to contain all these facilities’.

‘Material Handling’ refers to the ‘moving of materials from the store room to the machine and from one machine to the next during the process of manufacture’. It is also defined as the ‘art and science of moving, packing and storing of products in any form’. It is a specialised activity for a modern manufacturing concern, with 50 to 75% of the cost of production. This cost can be reduced by proper section, operation and maintenance of material handling

devices. Material handling devices increases the output, improves quality, speeds up the deliveries and decreases the cost of production. Hence, material handling is a prime consideration in the designing new plant and several existing plants.

Product design

Product design deals with conversion of ideas into reality. Every business organisation have to design, develop and introduce new products as a survival and growth strategy. Developing the new products and launching them in the market is the biggest challenge faced by the organisations. The entire process of need identification to physical manufactures of product involves three functions— Design and Marketing, Product, Development, and manufacturing. Product Development translates the needs of customers given by marketing into technical specifications and designing the various features into the product to these specifications. Manufacturing has the responsibility of selecting the processes by which the product can be manufactured. Product design and development provides link between marketing, customer needs and expectations and the activities required to manufacture the product.

Process design

Process design is a macroscopic decision-making of an overall process route for converting the raw material into finished goods. These decisions encompass the selection of a process, choice of technology, process flow analysis and layout of the facilities. Hence, the important decisions in process design are to analyse the workflow for converting raw material into finished product and to select the workstation for each included in the workflow.

Production planning and control

Production planning and control can be defined as the process of planning the production in advance, setting the exact route of each item, fixing the starting and finishing dates for each item, to give production orders to shops and to follow-up the progress of products according to orders. The principle of production planning and control lies in the statement 'First Plan Your Work and then Work on Your Plan'. Main functions of production planning and control include Planning, Routing, Scheduling, Dispatching and Follow-up.

Planning is deciding in advance what to do, how to do it, when to do it and who is to do it. Planning bridges the gap from where we are, to where we want to go. It makes it possible for things to occur which would not otherwise happen.

Routing may be defined as the selection of path, which each part of the product will follow, which being transformed from raw material to finished products. Routing determines the most advantageous path to be followed for department to department and machine to machine till raw material gets its final shape.

Scheduling determines the programme for the operations. Scheduling may be defined as 'the fixation of time and date for each operation' as well as it determines the sequence of operations to be followed.

Dispatching is concerned with the starting the processes. It gives necessary authority so as to start a particular work, which has been already been planned under 'Routing' and 'Scheduling'. Therefore, dispatching is 'Release of orders and instruction for the starting of production for any item in acceptance with the Route sheet and Schedule Charts'.

The function of Follow-up is to report daily the progress of work in each shop in a prescribed proforma and to investigate the causes of deviations from the planned performance.

Quality control (QC)

Quality Control may be defined as 'a system that is used to maintain a desired level of quality in a product or service'. It is a systematic control of various factors that affect the quality of the product. Quality Control aims at prevention of defects at the source, relies on effective feedback system and corrective action procedure. Quality Control can also be defined as 'that Industrial Management technique by means of which product of uniform acceptable quality is manufactured'. It is the entire collection of activities, which ensures that the operation will produce the optimum quality products at minimum cost.

The main objectives of Quality Control are:

- To improve the companies income by making the production more acceptable to the customers i.e. by providing long life, greater usefulness, maintainability, etc.
- To reduce companies cost through reduction of losses due to defects.
- To achieve interchangeability of manufacture in large-scale production.
- To produce optimal quality at reduced price.
- To ensure satisfaction of customers with productions or services or high quality level, to build customer good will, confidence and reputation of manufacturer.
- To make inspection prompt to ensure quality control.
- To check the variation during manufacturing.

Materials management

Materials Management is that aspect of management function, which is primarily concerned with the acquisition, control, and use of materials needed and flow of goods and services connected with the production process having some predetermined objectives in view.

The main objectives of Material Management are:

- To minimise material cost.
- To purchase, receive, transport and store materials efficiently and to reduce the related cost.
- To cut down costs through simplification, standardisation, value analysis, import substitution, etc.
- To trace new sources of supply and to develop cordial relations with them in order to ensure continuous supply at reasonable rates.
- To reduce investment tied in the inventories for use in other productive purposes and to develop high inventory turnover ratios

Maintenance management

In modern industry, equipment and machinery are a very important part of the total productive effort. Therefore their idleness or downtime becomes are very expensive. Hence, it is very important that the plant machinery should be properly maintained.

The main objectives of Maintenance Management are:

- To achieve minimum breakdown and to keep the plant in good working condition at the lowest possible cost.
- To keep the machines and other facilities in such a condition that permits them to be used at their optimal capacity without interruption.
- To ensure the availability of the machines, buildings and services required by other sections of the factory for the performance of their functions at optimal return on investment.

Summary

- Operation is that part of an organisation, which is concerned with the transformation of a range of inputs into the required output (services) having the requisite quality level.
- An operation was defined in terms of the mission it serves for the organisation, technology it employs and the human and managerial processes it involves.
- Operations in an organisation can be categorised into manufacturing operations and service operations.
- Operation managers are concerned with planning, organising, and controlling the activities, which affect human behaviour through models.
- Planning is the activity that establishes a course of action and guide future decision-making.
- Organising is the activities that establish a structure of tasks and authority.
- Controlling is the activities that assure the actual performance in accordance with planned performance.
- Joseph G .Monks defines Operations Management as the process whereby resources, flowing within a defined system, are combined and transformed by a controlled manner to add value in accordance with policies communicated by management.
- Operations Management concern with the conversion of inputs into outputs, using physical resources, so as to provide the desired utilities to the customer while meeting the other organisational objectives of effectiveness, efficiency and adoptability.

Self Assessment

1. _____ is the process, which combines and transforms various resources used in the operations subsystem of the organisation into value added services in a controlled manner as per the policies of the organisation.
 - a. Management
 - b. Business
 - c. Strategy
 - d. Economics

2. The set of interrelated management activities, which are involved in manufacturing certain products, is called as _____ management.
 - a. cost
 - b. operation
 - c. planning
 - d. production

3. Which of the following statements is true?
 - a. Operations in an organisation can be categorised into manufacturing operations and service operations.
 - b. Operations in an organisation can be categorised into production operations and systems operations.
 - c. Strategies in an organisation can be categorised into manufacturing operations and service operations.
 - d. Planning in an organisation can be categorised into manufacturing operations and service operations.

4. _____ is the activity that establishes a course of action and guide future decision-making.
 - a. Scheduling
 - b. Controlling
 - c. Planning
 - d. Organising

5. Which of the following are the activities that establish a structure of tasks and authority?
 - a. Scheduling
 - b. Controlling
 - c. Planning
 - d. Organising

6. _____ is the activities that assure the actual performance in accordance with planned performance.
 - a. Controlling
 - b. Scheduling
 - c. Planning
 - d. Organising

7. Resources are the human, material and capital inputs to the _____ process.
- production
 - manufacturing
 - operation
 - control
8. _____ are the arrangement of components designed to achieve objectives according to the plan.
- Process
 - Facilities
 - Systems**
 - Resources
9. _____ management is concerned with the achievement of both satisfactory customer service and resource utilisation.
- Operations**
 - Production
 - Financial
 - Resource
10. _____ refers to the physical arrangement of facilities.
- System design
 - System layout
 - Plant layout**
 - Design layout

Chapter II

Production Processes, Manufacturing and Service Operations

Aim

The aim of this chapter is to:

- introduce the terms ‘production process’, ‘manufacturing operations’ and ‘service operations’
- enlist the characteristics of manufacturing and service operations
- explain the responsibilities of operations manager in manufacturing and service operations

Objectives

The objectives of this chapter are to:

- explain the similarities between manufacturing and service operations
- differentiate between manufacturing and service operations
- elucidate the meaning of production process, manufacturing and service operations

Learning outcome

At the end of this chapter, you will be able to:

- comprehend the challenges faced by the operations manager
- understand the characteristics of service operations and manufacturing operations
- distinguish between manufacturing and service operations

2.1 Introduction

The way that businesses create products and services is known as the production process. A firm must purchase all the necessary inputs and then transform them into the product (outputs) that it wishes to sell. For instance, a football shirt manufacturer must buy the fabric, pay someone for a design, invest in machinery, rent a factory and employ workers in order for the football shirts to be made and then sold.

How well-organised a firm is at undertaking transformation process will determine its success is known as the productive efficiency of a firm and it will want to be as efficient as possible in transforming its inputs into outputs (i.e., using the minimum number of inputs as possible to achieve a set amount of output), this will reduce the cost per unit of production and allow the firm to sell at a lower price.

Ultimately, the objective of the production process is to create goods and services that meet the needs and wants of customers.

The needs and wants of customers will be met if a business can produce the correct number of products, in the shortest possible time, to the best quality and all at a competitive price.

2.2 Production Processes

Products are goods and services produced and processes are the facilities, skills and technologies used to produce them.

Production processes are essential to produce products and the available processes limit what products can be produced.

Production or operations function of an industrial enterprise is also known as conversion process or transformation process which transforms some of the inputs into outputs which are useful for the consumers.

Manufacturing Operations and Service Operations

The field of operations can be divided into manufacturing and service operations.

Manufacturing operations: Manufacturing operations or processes convert inputs into tangible outputs.

Manufacturing processes are primary processes and can be grouped under three basic categories, viz., forming, Machining and Assembly. Forming includes casting, forging, stamping, embossing, spinning etc. Machining includes metal removal by turning, drilling, milling, grinding, shaping, boring etc, it also includes chip less machining processes such as electro discharge machining (EDM), electromechanical machining (ECM), chemical milling, laser drilling etc. Assembly processes includes joining of parts, i.e., welding, riveting, fastening with bolts and nuts and joining by use of adhesive. Objectives of Manufacturing Operations are as follows:

- To give tools and advices for establishing manufacturing processes
- To show some alternative methods for reducing the cost of the manufacturing process
- To show how to estimate manufacturing cost and running cost of any manufacturing process

Operation 1

Raw materials: Collect and store the raw materials: Scrap or sponge iron: Where we get it, at what price, how do we store it, what quality is usually needed, how many people do we put on this task: Salary, outsourcing, qualifications, safety regulations and so on.

Operation 2

Melting: Sponge iron is melt in an electric arc furnace: What is the cost of the furnace, where do we implement it, What is the cost of the energy, how many people on this work station, how many quantities can we manage in one hour and how many quantities do we get by the end?

Operation 3

Refining: The melting metal is refined. It means that we separate the chemical elements in order to get the specific steel we need. How do we operate this separation, qualifications wanted, Do we need a chemist for controlling the process?

Operation 4

Casting: The liquid steel is cast in products such as billets: A new list of questions

Operation 5

Rolling: The billets are heated at 1200c and then rolled in order to get the plates: A new list of question

Service operations: Service operations or non manufacturing operations which also convert set of inputs into set of outputs which are intangible. It can be classified into standard services and custom services according to degree of standardisation of their outputs and /or the processes they perform, such as wholesale distribution and freight transportation etc. An operation does not necessarily provide only service or only goods. Facilitating goods may be provided with services and facilitating services may be provided with goods, for example, Servicing automobiles may include the replacement of some parts.

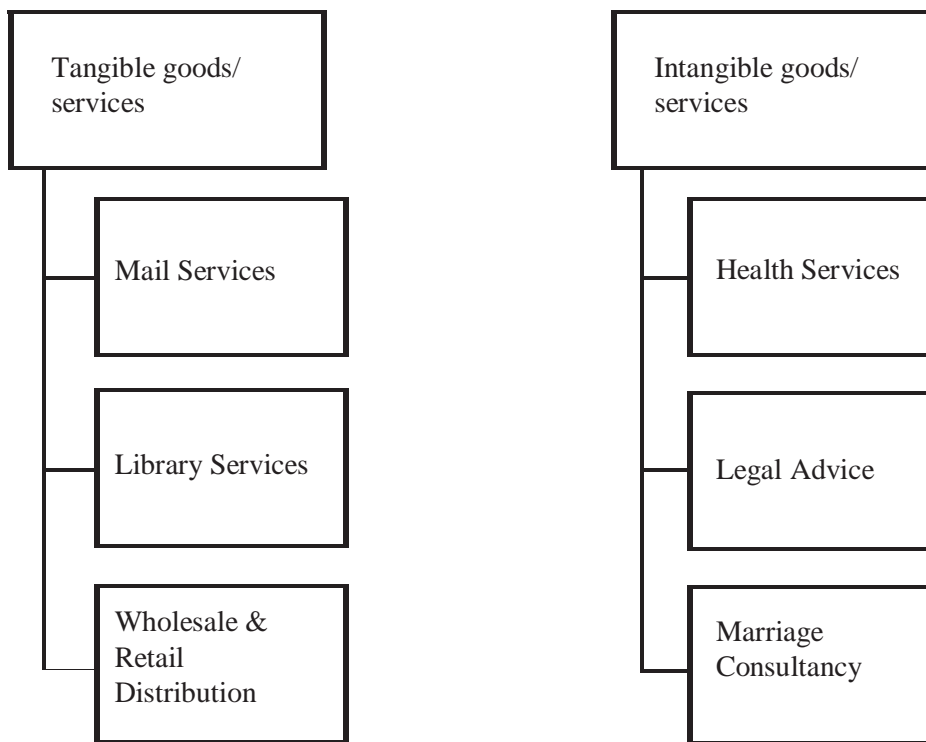

Fig. 2.1 Examples of tangible and intangible goods/services

Differences between manufacturing and service operations

The below mentioned table discusses the difference between manufacturing operations and service operations.

Manufacturing operations	Service operations
In Manufacturing operations, productivity can be measured.	In Service operations, it is uncommon to measure the productivity.
Outputs are tangible in nature.	Outputs are intangible in nature.
Quality standards are easily established.	It is difficult establish quality standards in service operations

Less customer contact with person who is involved in manufacturing process.	Customers have more contact with persons who provide services. In continuous production of standard products, it can accumulate or decrease inventory of finished products.
In service operations, it can not produce outputs that can be stored because they are intangible in nature.	
The proportion of expenses required for material handling is more.	The proportion of expenses in services operations is very less.
Investment in assets such as facilities, equipments and inventory are higher.	Investment in assets and inventory is less as compared to manufacturing operations.
These are depending more heavily on maintenance and repair works.	In service operations the maintenance is not required as the services are intangible.
MO having longer lead times.	SO having shorter lead times.
These are capital intensive	These are labor intensive

Table 2.1 Difference between manufacturing operations and service operations

Similarities between manufacturing and services:

Despite many differences, there are some similarities between manufacturing and service operations which are compelling. The similarities are;

- Both types of organisations (manufacturing and service) do not just produce or offer goods/services. They normally provide package of goods and services. e.g. customers expect both good service and good food at a restaurant and both are required form a retailer.
- Even though service providers cannot inventory their outputs, they must inventory the inputs for their service outputs.
- As for customer contact, there are some services, which have little outside customer contact such as the back room operations of a bank or a baggage handling area at an airport.

Characteristics of Manufacturing

Various characteristics of manufacturing are discussed below.

Specialisation	Mechanisation	Use of Technology of Industrial Engineering	Use of Computers and Data Processing Equipments	Use of Scientific Methods
<p>Specialisation means division of work or effort and this operates both at workers and management level. The result of specialization is low cost of production and improved quality. At management level the efforts are divided into various special functions such as Research and development design, engineering, finance, accounting, sales, purchase, personnel, maintenance etc</p>	<p>Mechanisation replaces human labor by machine power. The human skill is transferred to machine tools which carryout various manufacturing operations. Advanced form of mechanization is known as Automation</p>	<p>Industrial engineers have been able to devise improvements and to increase productivity by elimination of waste and inefficiency, thereby increasing production and reducing costs.</p>	<p>Widespread use of computers in manufacturing industries has made possible, the handling of enormous amounts of data and the solving of complex mathematical problems at high speed. The range of application of computers include product design, control of manufacturing process, production and inventory control, quality control, maintenance control etc.</p>	<p>Industrial engineering, operations research or management science involves quantitative methods and techniques to solve both engineering and managerial problems. Operations research is an aid in decision making based on quantitative analysis.</p>

Table 2.2 Characteristics of Manufacturing

Characteristics of Services

Intangibility

Most services are intangible. Tangible goods can be seen, touched, smelled, heard or tested prior to purchase unlike services. Most services are performances.

Perishability

It means the service cannot be inventoried or stored. Most services, because they are simultaneously produced and consumed are considered as perishable. e.g. Hotel rooms, seats on an airplane or in movie theatre cannot be stored and retrieved for later use.

Inseparability

Inseparability refers to the simultaneous production and consumption of services. Goods can be produced and then sold later whereas services cannot. They can consume only when they are produced.

Variability

Variability refers to the unwanted or random levels of service quality customers receive when they patronise a service because of the human element involved in providing a service.

Various service employees will perform the same service differently and even the same service employee will provide varying levels form one time to another.

Challenges faced by Operations Managers

The key challenges facing service operations managers are;

- Managing multiple customers
- Understanding the service concept
- Managing the outcome and experience
- Managing in real time
- Knowing, implementing and influencing strategy
- Continually improving operations
- Encouraging innovation
- Managing short term and long term issues simultaneously

These are briefly explained below;

Managing multiple customers

Many service organisations often serve heterogeneous group of customers, in different ways and different types of customers. Understanding who the curious customers are, understanding their needs and expectations, developing relationships with them and managing the various customers are key tasks for service operations managers.

Understanding the service concepts

There may be differing views about what service an organisation is selling and/or the customer is buying. Articulating and communicating the service concept is critical for classifying the organisation service product to all its customers and for ensuring that it can be delivered to customer specification.

Managing the outcome and experience

For many services, there is no clear boundary between experience and the outcome. Example customers in a restaurant are buying both the meal and the way they are served. The intangible nature of the experience provides particular problems for both specification and control.

Managing the real time

Many services happen in real time. They cannot be delayed or put-off. Example, aircrafts coming into land cannot be put on hold while controllers take a break

Also, during a service encounter, it is not possible to undo what is done. In manufacturing operations it is possible to scrap defective products and remake them, but in service operations it is not possible to undo defective service rendered to a customer.

Knowing, implementing and influencing strategy

- Operations which are the doing part of the business are also responsible for implementing strategy of the service organisation. Service operations managers must understand their role, not only in implementing strategy but also in contributing to it or influencing the strategy.
- Service operations managers need to provide platform for their organisations for competitive advantage through competence in service operations.

Continually improving operations

Service operations managers are faced with a challenge of how continually to improve and develop their real improvements. They should manage the increased complexity resulting from change and also improve efficiency as well as quality of service operations.

Encouraging innovations

Innovation looks for what is new rather than improving the existing service operations usually require elements of financial risk because innovations require time and money and personal risk for service managers champion change putting their reputation on the line.

Managing short term and long term issues simultaneously

- Organisations are under pressure to perform in the short term which leaves little time for medium term operational improvement or long term strategic planning.
- Many service operations managers focus their time and effort on managing day to day operations to ensure the delivery of an appropriate quality of service operations management are frequently neglected .

Summary

- Products are goods and services produced and processes are the facilities, skills and technologies used to produce them.
- The objective of the production process is to create goods and services that meet the needs and wants of customers.
- Manufacturing operations or processes convert inputs into tangible outputs.
- Forming includes casting, forging, stamping, embossing, spinning etc.
- Machining includes metal removal by turning, drilling, milling, grinding, shaping, boring etc, it also includes chipless machining processes such as electro discharge machining (EDM), electromechanical machining (ECM), chemical milling, laser drilling etc
- The Production operations are divided in manufacturing and service operations.
- In every organisation the operation manager facing some difficulties and challenges in front of him to achieve an organisations goal.

Self Assessment

1. The ultimate objective of _____ is to create goods and services that meets the needs and wants of the customers.
 - a. manufacturing
 - b. production process
 - c. service operation
 - d. transformation

2. In manufacturing operations, _____ includes casting, forging, stamping, embossing, spinning.
 - a. transformation
 - b. forming
 - c. deforming
 - d. machining

3. In manufacturing process, _____ includes metal removal by turning, drilling, milling, grinding, shaping, boring.
 - a. assembling
 - b. forming
 - c. machining
 - d. deforming

4. _____ means division of work or effort and this operates both, at workers and management level.
 - a. Specialisation
 - b. Mechanisation
 - c. Transformation
 - d. Operation

5. Mail Service, Library service is considered as _____ goods/service.
 - a. intangible
 - b. standard
 - c. tangible
 - d. customised

6. The unwanted or random levels of service quality customers receive when they patronise a service because of the human element involved in providing a service is known as _____.
 - a. inseparability
 - b. variability
 - c. perishability
 - d. uniformity

7. Advanced form of mechanisation is known as _____.
 - a. Auto-mechanisation
 - b. Advancement
 - c. Computerisation
 - d. Automation

8. Melting, refining, casting are the processes of _____.
 - a. service operation
 - b. manufacturing operation
 - c. production
 - d. processing

9. Which of the following is not the characteristic of Service operation?
 - a. Intagibility
 - b. Inseparability
 - c. Variability
 - d. Mechanisation

10. Operations research is an aid in decision making based on _____.
 - a. qualitative analysis
 - b. quantitative analysis
 - c. statistical analysis
 - d. methodology

Chapter III

Production, Planning and Control

Aim

The aim of this chapter is to:

- explain the idea of production planning and production control
- introduce the term ‘production planning
- enlist the functions of production planning and control

Objectives

The objectives of this chapter are to:

- explain the scope and principles of production planning and control
- enlist different levels of production planning system
- define the term production planning and control

Learning outcome

At the end of this chapter, you will be able to:

- understand the factors determining production planning procedures
- identify the production planning system
- understand the scope and functions of production planning and control

3.1 Introduction

Production consists of a sequence of operations that transforms materials from a given form to a desired form (products). The highest efficiency in production is obtained by manufacturing the required quantity of products of the required quality, at the required time, by the best and cheapest method. To achieve this objective, production management employs production planning and control function which is a management tool that coordinates all manufacturing activities. The four factors, viz., Quantity, Quality, Time and Cost encompasses the production system of which production planning and control is the nerve centre or brain.

There are three stages in PPC:

- **Planning:** The choice from several alternatives of the best means of utilizing the resources available to achieve the desired objectives in the most efficient and economic manner.
- **Operations:** Performance in accordance with the details set out in the production plan.
- **Control:** The monitoring of performance through a feed back by comparing the results achieved with the planned targets so that performance can be improved through proper corrective action.

Planning Pre-planning & Active planning Action Control

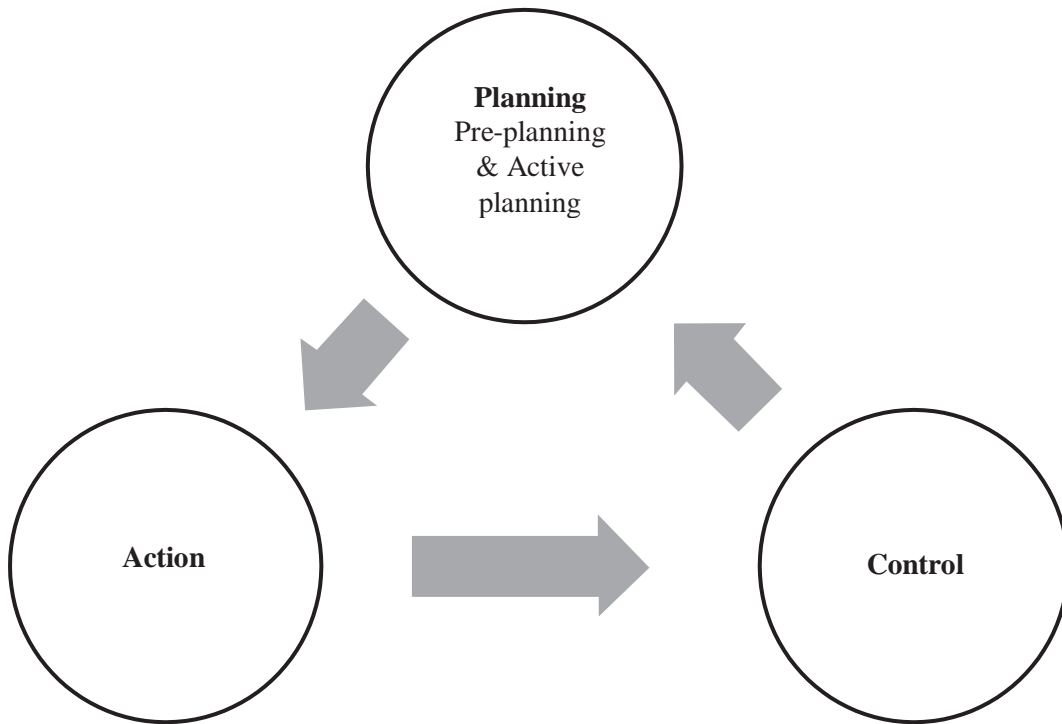

Fig. 3.1 Three stages in PPC

Hence, Production, Planning and Control may be defined as the planning, direction and coordination of the firms material and physical facilities towards the attainment of predetermined production objectives in the most economical manner. Production, planning and control (PPC) is referred to as operations planning and control because the production planning and control techniques used in production systems manufacturing tangible goods can also be employed in operations or services systems providing services. Production/operation planning and control involves the organisation and control of an overall manufacturing system to produce a product (or a service).

3.2 Objectives of Production Planning and Control

PPC function essentially consist of planning production in a manufacturing organisation before actual production activities start and exercising control activities to ensure that the planned production is realised in terms of quantity, quality, delivery schedule and cost of production. Objectives of PPC are to deliver quality goods in required quantities to the customer in the required delivery schedule to achieve maximum customer satisfaction and minimum possible cost

- To ensure maximum utilisation of all resources
- To ensure production of quality products
- To minimise the product through put time or production/manufacturing cycle time
- To maintain optimum inventory levels
- To maintain flexibility in manufacturing operations
- To co-ordinate between labor machines and various supporting departments
- To plan for capacities between labor and machines and various supporting departments
- To plan for plant capacities for future requirements
- To ensure effective cost reduction and cost control
- To prepare production schedules and ensure that promised delivery dates are met
- To produce effective results for least total cost
- The ultimate objective is to contribute to profit of the enterprise

3.3 Scope of Production Planning and Control

Production Planning and Control encompasses the following areas:

- **Materials:** Planning for procurement of raw materials, components and spare parts in the right quantities and specifications at the right time from the right time form the right source at the right price. Purchasing, storage, inventory control, standardisation, variety reduction, value analysis and inspection are the other activities associated with materials.
- **Methods:** It helps choosing the best method of processing from several alternatives. It also includes determining the best sequence of operations and planning for tooling, jigs and fixtures etc.
- **Machines and Equipments:** Manufacturing methods are related to production facilities available in the production system. It involves facilities planning, capacity planning allocation and utilisation of plant and equipments, machines etc.
- **Manpower:** Planning for man power (labor, supervisory and managerial levels) having appropriate skills and expertise.
- **Routing:** Determining flow of work material handling in the part, and sequence of operation or processing steps: This is related to consideration of appropriate shop layout and plant layout, temporary storage locations for raw materials, components and semi finished goods and of materials handling system.
- **Estimating:** It is the process of establishing operations time leading to fixation of performance standards both for workers and machines.
- **Loading and Scheduling:** Machine loading is allocation of jobs to machines in conjunction with routing and with due consideration for capacity of machines and priority for jobs in order to utilise the machines to the maximum possible extent.
- **Scheduling** ensures that parts, sub assemblies and finished products are completed as per required delivery dates. It provides a time table of manufacturing activities. It ensures balanced load on all work centers and ensures even flow of work through the manufacturing facilities.
- **Dispatching:** This is concerned with the execution of the planning functions. It gives necessary authority to start a particular work which has already been planned under routing and scheduling functions. Dispatching is release of orders and instructions for the starting of production in accordance with the route sheets and schedule charts.

- **Expediting:** It means chasing, follow up or progressing which is down after dispatching function. It keeps a close liaison with scheduling in order to provide an efficient feedback and prompt review of targets and schedules.
- **Inspection:** This function is related to maintenance of quality in production and of evaluating the efficiency of the processes, methods and labor so that improvements can be made to achieve the quality standards set by product design.
- **Evaluating:** The objective of evaluation is to improve performance. Performance of machines, processes and labor is evaluated to improve the same.
- **Cost Control:** Manufacturing cost is controlled by wastage reduction, value analysis, inventory control and efficient utilization of all resources.

3.4 Principles of Production Planning and Control

Following are the principles of production planning and control

- Type of production determines the kind of production planning and control the system needed.
- The number of parts involved in the product affects expenses of operating PPC department.
- Complexity of PPC function varies with the number of assemblies involved.
- Time is a common denominator for all scheduling activities.
- Size of the plant has relatively little to do with the type of the PPC system needed.
- PPC permits ‘management by exception’.
- Cost control should be a byproduct of PPC function.
- The highest efficiency in production is obtained by manufacturing the required quantity of a product of the required quality, at the required time by the best and cheapest method. PPC is a tool to coordinate all manufacturing activities in a production/operating system.

3.5 Functions of Production Planning and Control

The main functions of production planning are as shown below:

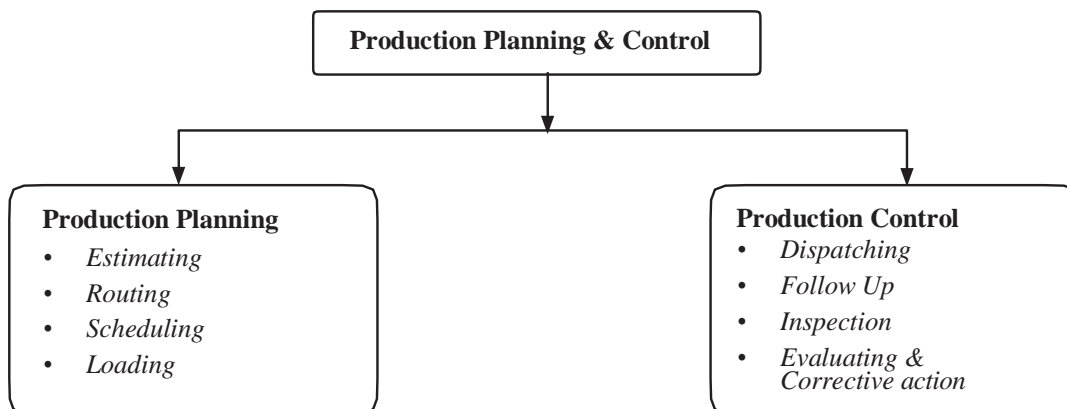

Fig. 3.2 Functions of production planning and control

Estimating

- It involves deciding the quantity of products to be produced and cost involved in it on the basis of sales forecast.
- Estimating manpower, machine capacity and materials required to meet the planned production targets are the key activities before budgeting for resources.

Routing

- This is the process of determining the sequence of operations to be performed in the production process. Routing determines what work must be done, where and how?
- Routing information is provided by product or process engineering function and it is useful to prepare machine loading charts and schedules.
- Route sheets: These are the documents providing information and instruction for converting the raw materials into finished products.

Scheduling

- It involves fixing priorities for each job and determining the starting time and finishing time for each operation, the starting dates and finishing dates for each part, sub assembly and final assembly.
- Scheduling lays down a time table for production indicating the total time required for the manufacture of a product and also the time required for carrying out the operation for each part on each machine or equipment.

Loading

- Facility loading means loading of facility or work centre and deciding which jobs to be assigned to which work centre or machine. Loading is the process of converting operation schedules into practice.
- Machine loading is the process of assigning specific jobs to machines, men or work centers based in relative priorities and capacity utilization.
- A machine loading chart is prepared showing the planned utilization of men and machines by allocating the jobs to machines or workers as per priority sequencing established at the time of scheduling.

The control functions are mentioned below:

Dispatching

- It is defined as, setting production activities in motion through the release of orders and instructions in accordance with the previously planned time schedules and routings.
- Dispatching function includes Collecting tools, issuing job orders, obtaining inspection schedules, internal material handling and movement of materials to inspection area after completing the operation, returning jigs and fixtures etc.

Follow up

- Expediting or progressing ensures that the work is carried out as per plan and delivery scheduling are met.
- Progressing includes activities such as status reporting, attending to bottlenecks or holdups in production and removing the same, controlling variation and deviations from planned performance levels, following up and monitoring progress of work through all stages of production, coordinating with purchase, stores, tool room and maintenance departments and modifying the production plans and re-plan if necessary. In short, production planning and control function is concerned with decision making regarding:
 - ① What to produce: product planning and development includes product design.
 - ① How to produce: process planning, material planning, tool planning etc.
 - ① Where to produce: facilities planning, capacity planning and sub contracting planning.
 - ① When to produce: production scheduling and machine loading.
 - ① Who will produce: man power planning.
 - ① How much to produce: Planning for quantity, economic batch size etc.

Levels of Production Planning System

Planning Horizon	Inputs	Plans/ Schedule	Outputs
Long-range planning (Strategic planning)	<ul style="list-style-type: none"> • Long-range demand forecast. • Availability of funds and business analysis. • Capacity data and analysis. 	<ul style="list-style-type: none"> • Long-range capacity plan. 	<ul style="list-style-type: none"> • Production facility plans. • Major subcontract plans. • Major machinery and process plans.
Intermediate range (tactical planning)	<ul style="list-style-type: none"> • Intermediate range demand forecast. 	<ul style="list-style-type: none"> • Aggregate capacity. 	<ul style="list-style-type: none"> • Employment plan. • Machinery and utility plan. • Subcontract and material supply contracts.
Short range (Operational planning)	<ul style="list-style-type: none"> • Short range demand forecast. • On hand customer orders. • Other orders. • Availability of material from suppliers. 	<ul style="list-style-type: none"> • Master Production Schedules (MPS). • Capacity requirement planning (CRP). • Material requirement planning (MRP). 	<ul style="list-style-type: none"> • Short range production schedules for end products. • Short range schedules for parts, components, sub-assemblies. • Short range plan for purchasing materials. • Short range shop floor plans.

Table 3.1 Tabular representation of different levels of production planning system

3.6 Benefits of Production Planning and Control Function

PPC function is the nerve centre or heart of the production/operations management function.

- It coordinates all phases of the production/operating system.
- An efficient PPC function results in higher quality, better utilization of resources, reduced inventories, reduced manufacturing cycle time, faster delivery, better customer service, lower production costs and lower capital investment and higher customer satisfaction.
- Efficient utilization of resources results in higher productivity an economy of production, timely delivery and right quality of goods/services at the right cost will improve customer satisfaction.
- Minimization of breakdown of machines, plant and equipments plant facilities will improve employee discipline and morale.
- An efficient PPC system enables the firm to improve its sales turnover, market share and profitability and provides a competitive advantage for the firm due to balanced inventory levels and higher quality, flexibility and dependability and lower prices which are the performance factors for the firm.

Limitations of Production Planning and Control Function

Following are the limitations of production planning and control function

- PPC function is based on certain assumptions or forecasts of customers' demand plant capacity, availability of materials; power etc. if these assumptions go wrong, PPC becomes ineffective.
- Employees may resist changes in production levels set as per production plans if such plans are rigid.
- The production planning process is time consuming when it is necessary to carry out routing and scheduling functions for large and complex products consisting of a large no of parts going into the product.
- PPC function becomes extremely difficult when the environmental factors change very rapidly such as technology, customers taste regarding fashion or style of products needed, government policy and controls change frequently, stoppages of power supply by electricity boards due to power cuts, break in supply chain due to natural calamities such as floods, earthquakes, war etc.

Production Planning and Control in Different Production System

The manufacturing process is classified into four types.

- Job production: Herein one or few units of the products are produced as per the requirement and specification of the customer. Production is to meet the delivery schedule and costs are fixed prior to the contract.
- Batch production: In this, limited quantities of each of the different types of products are manufactured on same set of machines. Different products are produced separately one after the other.
- Mass or flow production: Under this, the production run is conducted on a set of machines arranged according to the sequence of operations. A huge quantity of same product is manufactured at a time and is stocked for sale. Different product will require different manufacturing lines. Since one line can produce only one type of product, this process is also called as line flow.
- Process production: Under this, the production run is conducted for an indefinite period.

PPC in job production

- Job production involves manufacture of products to meet specific customer requirements of special orders. The quantity involved is usually small.
- Example: Manufacture of large turbo generators, boilers, steam engines, processing, equipments, material handling equipments, ship building etc.
- Under Job production we have three types according to the regularity of manufacturing namely,
 - A small number of products produced only once
 - A small number of products produced intermittently when the need arises
 - A small number of products produced periodically at known interval of time
- PPC function is relatively difficult in Job production because of the following reasons:
 - Every job order is of different nature and has different sequence of operation. There is no standardised routing for job orders.
 - Specific job orders are assigned to different work stations as per availability of capacity.
 - Production schedules drawn depend on the relative priority assigned to various job orders.
 - Scheduling is dependent on assessment of production times and estimating is based on judgment.

PPC in batch production or intermittent production

Batch production is the manufacture of a number of identical articles either to meet a specific order or to satisfy continuous demand. The decisions regarding tooling and jigs and fixtures are dependent on the quantities involved in the production batch. In batch production too there can be three types namely;

- A batch produced only once
- A batch produced repeatedly at regular intervals, when the need arises
- A batch produced periodically at known intervals, to satisfy continuous demand

PPC in continuous production

Continuous production is normally associated with large quantities of production and with high rate of demand. Continuous production is justified when the rate of production can be sustained by the market.

Two types of continuous production can be Mass production and Flow production.

- In Mass production, a large number of identical articles is produced, but in spite of advanced mechanization and tooling, the equipment need not be specially designed for the component to be manufactured.
- In Flow production, the plant and equipment and layout have been primarily designed to manufacture a particular product.

A decision to switch over to a different kind of product needs basic changes in the equipments and the layout, especially when special purpose machines and complex material handling systems are used. PPC in continuous production is usually simpler than in job or batch production. The output is either limited by available capacity or regulated within given limits to conform to production targets based on periodic sales forecasts.

PPC in process industry

PPC in process industry is relatively simple. Routing is automatic and uniform. Standard processes and specialised equipments are used. As the products are standardised and goods are produced to stock and sell, scheduling is easy. Departmental schedules are derived from master production schedules. Dispatching involves issue of repetitive orders to ensure a steady flow of materials throughout the plant. The main task of PPC in process industry is to maintain a continuous and uniform flow of work at the predetermined rate in order to utilise the plant and equipments fully and to complete the production in time.

Factors Affecting the Choice of Manufacturing Process

Following factors need to be considered before making a choice of manufacturing process.

Effect of volume/variety: this is one of the major considerations in selection of manufacturing process. When the volume is low and variety is high, intermittent process is most suitable and with increase in volume and reduction in variety continuous process become suitable. The following figure indicates the choice of process as a function of repetitiveness. Degree of repetitiveness is determined by dividing volume of goods by variety.

Capacity of the plant: Projected sales volume is the key factor to make a choice between batch and line process. In case of line process, fixed costs are substantially higher than variable costs. The reverse is true for batch process thus at low volume it would be cheaper to install and maintain a batch process and line process becomes economical at higher volumes.

Lead time: The continuous process normally yields faster deliveries as compared to batch process. Therefore lead-time and level of competition certainly influence the choice of production process.

Flexibility and efficiency: The manufacturing process needs to be flexible enough to adapt contemplated changes and volume of production should be large enough to lower costs.

Summary

- Production, planning and control (PPC) is referred to as operations planning and control because the production planning and control techniques used in production systems manufacturing tangible goods can also be employed in operations or services systems providing services.
- Three stages in production planning and control functions are:
- Planning: Choosing the best course of action among several alternatives.
- Operations: Execution as per plan.
- Control: Maintaining the performance by comparing the actual results with performance standards set and taking appropriate corrective action if necessary to reduce variance.
- There are 3 phases of PPC that is Planning, Action and Control.
- The control functions are Dispatch and Follow up.

Self Assessment

1. _____ is a sequence of an operation that transforms materials from a given form to a desired form (products).
 - a. Operation
 - b. Transformation
 - c. Production
 - d. Control

2. Determining a flow of work material handling in the part, and sequence of operation or processing steps is known as,_____.
 - a. estimating
 - b. loading
 - c. scheduling
 - d. routing

3. _____ means chasing, follow up or progressing which is down after dispatching function.
 - a. Scheduling
 - b. Routing
 - c. Expediting
 - d. Loading

4. _____ is concerned with the execution of the planning functions; it gives necessary authority to start a particular work which has already been planned under routing and scheduling functions.
 - a. Dispatching
 - b. Expediting
 - c. Evaluating
 - d. Routing

5. _____ function is related to maintenance of quality in production and of evaluating the efficiency of the processes, methods and labor so that improvements can be made to achieve the quality standards set by product design.
 - a. Expediting
 - b. Evaluating
 - c. Routing
 - d. Inspection

6. Which of the following is related to consideration of appropriate shop layout and plant layout, temporary storage locations for raw materials, components and semi finished goods and of materials handling system?
 - a. Routing
 - b. Estimating
 - c. Loading
 - d. Scheduling

7. This involves planning for quantity, determination of product, mix routing, scheduling, material planning, process planning, capacity planning and tool planning.
 - a. Pre-planning
 - b. Active planning
 - c. Control phase
 - d. Action phase

8. Master Production Schedules (MPS), Capacity Requirement Planning (CRP), Material Requirement Planning (MRP) considered in which level of production system.
 - a. Short range level planning
 - b. Intermediate range planning
 - c. Long range planning
 - d. Mid-range planning

9. In production control function, the setting production activities in motion through the release of orders and instructions in accordance with the previously planned time schedules and routings.
 - a. Expediting
 - b. Dispatching
 - c. Loading
 - d. Scheduling

10. Which of the following is the type of production in which, limited quantities of each of the different types of products are manufactured on same set of machines?
 - a. Continuous
 - b. Batch
 - c. Job
 - d. Process

Chapter IV

Long Range Capacity Planning and Facility Location

Aim

The aim of this chapter is to:

- introduce the idea of long range capacity planning and facility location
- define capacity and capacity planning, short range, intermediate range and long range planning
- enlist various types of capacity

Objectives

The objectives of this chapter are to:

- discuss various determinants of effective capacity
- elucidate the concept of ‘facility location’
- explain the steps in location selection

Learning outcome

At the end of this chapter, you will be able to:

- understand the approaches to develop capacity alternatives
- enlist location factors
- understand the importance of capacity planning and facility location

4.1 Introduction

Capacity is known as the amount of output, that a system is capable over a specific period of time. Capacity is the upper limit or ceiling on the load that an operating unit can handle. Examples of Capacity measures:

Type of Organisation	Measures of Capacity	
	Inputs	Outputs
Manufacture	Machine hours per shift	Number of units of shifts
Hospital	Number of berths/beds	Number of patients treated
Airline	Number of planes or seats	Number of seat miles flown
Restaurant	Number of seats	Customer/time
Retailer	Area of store	Sales
Theatre	Number of seats	Customer/time

Table 4.1 Example of capacity measure

Capacity planning is the process of determining the production capacity needed by an organisation to meet changing demands for its products. It is the process used to determine how much capacity is needed (and when) in order to manufacture greater product or begin production of a new product. Capacity planning is central to the long term success of an organisation. Capacity planning is generally viewed in terms of three time horizons or durations.

- Long Range Capacity Planning which is usually having a time horizon of more than one or two years. It is carried out for productive resources which take a long time to acquire or dispose of such as buildings, equipment or facilities such as machinery, materials handling equipments and transportation vehicles etc.
- Intermediate Range Capacity Planning which has a time horizon or duration for the next 6-18 months. The intermediate range capacity may be varied by such alternatives such as hiring or laying off labour, purchasing or making new tools and minor equipments and outsourcing/subcontracting etc.
- Short Range Planning which has a time horizon or duration of less than one month. This is concerned with day to day planning such as daily scheduling of activities and machine loading or weekly scheduling process which involves making adjustments to eliminate the variance between planned output and actual output. It is concerned with overtime, transfer of personnel and changing the production routings.

Capacity planning can address following questions:

- How much long range capacity is needed?
- When additional capacity is needed?
- Where the production facilities should be located?
- What will be the layout and characteristics of the facilities should be?

A firm must live with its facility planning decisions for a long time, and these decisions affect:

- Operating efficiency.
- Economy of scale.
- Ease of scheduling.
- Maintenance costs.
- Profitability.

Capacity plans are made at two levels:

- Long-term Capacity Plans, which deals with investments in new facilities and equipments covering the requirements for at least two years into the future
- Short-term Capacity Plans which focuses on work force size, overtime budgets, inventories etc.

4.2 Long Range Capacity Planning

- Capacity planning that establishes some expectations about the capacity a company acquires and develops over time.
- Long term capacity planning is an important part of strategic planning of the firm. It establishes some expectations about the capacity a company acquires and develops over time which is vitally important to the company's strategic success.
- Companies which are in business for the long run must make continued investment in people, technology, research and development and capital assets (such as buildings, machinery and equipments etc).
- External environment conditions such as economic, political, technological, social and market conditions and forecast of future levels of demand provide important inputs into long term strategic planning and also into short term plans and decisions made by managers of the firm.

Managers must evaluate and consider trade-offs of a number of factors while establishing a long term capacity plan for their firms. Some of these factors are:

- Forecast growth in demand.
- Future upgrading of technology which may become necessary to gain competitive edge over others.
- Anticipated moves by competing firms.
- Reliance on learning curves without additional investment.
- Forecast of availability of funds for the future investments.
- The cost of new capacities and capacities which can provide economies of scale.

Capacity decisions have long term effects on many aspects of the business. Finance is affected because of the influence of capacity decisions on the level of capital investment and return on that investment. Production affected because capacity sets constraints within which operations must work to meet its objective of producing high quality goods or services at competitive cost and lead times.

Long range capacity decisions made in early years determine the current level of capital assets such as buildings machinery and equipments of the firm.

4.3 Estimating the Capacities of Existing Facilities

To estimate the capacities of existing facilities in a firm, it is necessary to know about the various types of capacity and the measures of capacity.

Production capacity

It is the maximum rate of production (or output) of an organisation. Several factors underlying the concept of capacity make its understanding and use somewhat complex. Variation in employee absenteeism, equipment breakdowns, vacations, holidays, delays in material procurement/delivery, work schedules, working hours, use of overtime, temporary workers, outsourcing etc., must be taken into account when estimating the production capacity.

Design capacity

Design capacity refers to the maximum output that can possibly be attained. It is the maximum rate of output achieved under ideal conditions.

Effective capacity

Effective capacity is the maximum possible output given a product mix, scheduling difficulties, machine maintenance, quality factors, absenteeism etc. Effective capacity is usually less than design capacity because of capacity losses due to realities such as product mix changes, need for periodic preventive maintenance of equipment, problems in scheduling and balancing operations, coffee breaks, lunch breaks and so on.

Maximum capacity

It is also known as Peak capacity, it is the maximum output that a facility can achieve under ideal conditions. Where capacity is measured relative to equipment alone, it is known as related capacity.

Measures of capacity

Different measures of capacity are applicable in different situations. For example, capacity of an automobile plant can be measured in terms of the number of automobiles produced per unit of time whereas capacity of a hospital is measured in terms of the number of patients that can be treated per day. Therefore, capacity of a facility can be either measured in terms of inputs.

An important measure of system effectiveness is the capacity utilisation rate which reveals how close a firm is to its best operating point i.e. design capacity.

$$\text{Capacity utilisation rate} = \frac{(\text{Capacity used (i.e. Actual output)})}{(\text{Best operating level (or design capacity)})}$$

Best operating level is the level of capacity for which the facility was designed and thus is the volume of output at which average unit cost is minimum.

Another measure of system effectiveness is efficiency which is the ratio of actual output to the effective capacity.

$$\text{Efficiency} = \frac{(\text{Actual Output})}{(\text{Effective Capacity})}$$

Determinants of Effective Capacity

Many decisions about design of the production system and operation of the production system may have an impact on capacity. The main factors relate to the following:

- facilities
- product or services
- process
- human resource considerations
- operations
- external forces

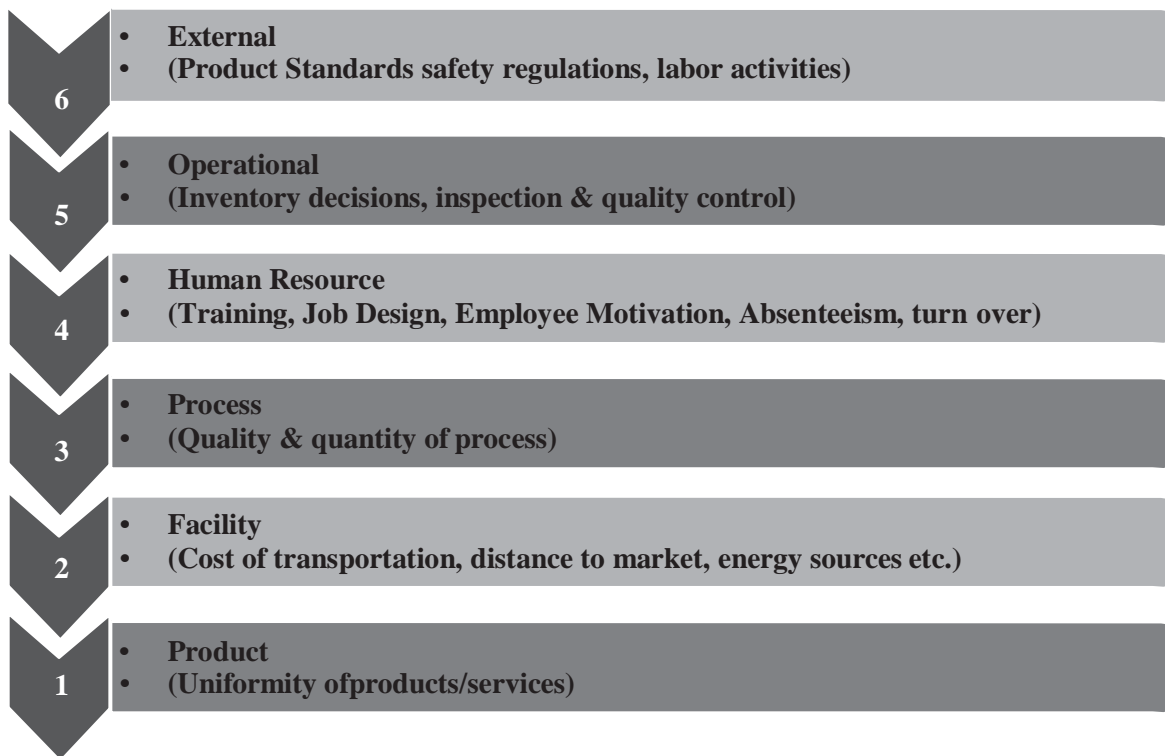

Fig. 4.1 Determinants of effective capacity

Forecasting Long-term Future Capacity Demand

- Long range capacity planning involves providing facilities such as land, buildings, machines, tools, equipments, materials, personnel, utilities.
- Planning and establishing a new production facility could take 5-10 yrs. and therefore such a facility would be expected to remain economically productive for another 15-20 yrs or so.
- Therefore, forecasting demand for the products or services to be produced from such a facility must cover a timer horizon of 10-30 yrs.
- But because of changes taking place in the external business environment forecast over such long periods of time are difficult to make and may not be reliable.

Forecasting production capacity for a product or service usually involves the following four steps:

- Estimate the total demand for a particular product from all producers
- Estimate the market share for the company for which capacity has to be forecasted
- Estimate the demand for the company by multiplying the total demand by its market share
- Translate the product and service demand for the company into capacity needs

Then the production capacity must be allocated to each product and service based on the best estimates of demand for each product and service.

However, the production capacity to be provided by a firm may not necessarily equal to the amount of product and services expected to be demanded.

There are several reasons for this:

- The firm may not have enough capital and other resources to satisfy all the demand.
- Because of uncertainties of forecast and the need to link production capacity to competitive priorities of the firm, a capacity cushion may have to be provided.
- A capacity cushion is an additional amount of production capacity over and above the required capacity to meet the expected demand.

Advantages of having capacity cushion are:

- Extra capacity to meet demand excess of forecasted demand
- Ability to satisfy peak demands
- Reduced production costs
- Product and volume flexibility
- Improved quality of products and services

Identifying and Analysing Sources of Capacity to Meet Future Capacity Needs

There are many ways available to a firm to change its capacity. Firms may either have shortage of capacity or excess capacity. The long range capacity needs of an organisation can be changed in the following ways:

Where present capacity is not sufficient to meet the forecast demand for the products and services, capacity can be expanded by:

- Subcontracting component parts, sub units or even entire products to other firms
- Acquiring other firms, facilities or resources
- Building new plants and buying equipments/machinery etc
- Expanding, modernising or modifying existing facilities
- Reactivating facilities which are on standby status

When the present capacity is in excess of the expected future needs, capacity can be reduced by:

- Selling off existing facilities, selling inventories and laying-off or transferring employees
- Placing some facilities on standby status and selling the inventories and laying off or transferring employers of such surplus facilities
- Developing and phasing in new products as other products decline, so that capacity rendered surplus can be made use of

4.6 Capacity Management

To enhance capacity management, the following approaches to capacity alternatives could be developed:

Designing flexibility into the system

- Designing flexible production system can offer potential benefits in long range capacity planning because of the risks inherent in long term forecast.
- When flexibility is built in the design of the system itself it would become easy to implement expansion plans later.
- Other factors to be considered in flexible design include layout of equipment, location and equipment selection, production planning, scheduling and inventory policies.

Differentiating between new and mature products or services

- Capacity requirements of mature products can be predicted more precisely and mature products may have limited life spans.
- The possible limited life span of the matured products or service may necessitate finding an alternative use for the resulting excess capacity at the end of the life span.
- On the other hand, new products tend to carry higher risk because the quantity demanded and duration of the demand cannot be predicted accurately.
- Therefore having flexibility becomes a more attractive option to production managers.

Taking a big picture approach to capacity changes

When developing capacity alternatives, a firm must consider how different parts of the system interrelate.

For example when the management of a five star hotel makes a decision to increase the number of rooms, it must also consider probable increased demand for parking lots, restaurant seating capacity, bigger dining hall and kitchen capacity, increase in no. of hotel staff and house-keeping staff etc.

Preparing to deal with 'chunks' of capacity

Usually capacity increased is often acquired in the form of fairly large chunks of capacity rather than small increments in capacity.

For example in a steel plant, the existing capacity, of a furnace may not be enough to meet the demand, but installing an additional furnace would result in having excess capacity because additional furnaces cannot be installed in small capacity chunks.

Attempting to smoothen out capacity requirements

- Having unevenness in capacity requirement can be problematic. E.g. during seasons of bad or extreme weathers, more and more people may tend use public transport vehicles for their travel rather than using their own vehicles.
- Consequently the public transportation system may tend to alternative between under utilisation and over utilisation.
- Demand for consumer products could vary partly because of chance factors because of seasonality.
- Seasonal variations can be predicted and hence can be better coped with than random variations.
- However seasonal variations can still pose problems because of their uneven demands on the production system.
- This problem of seasonality can be overcome by producing products having complementary demand patterns.
- If products having complementary demands patterns involve the use of the same resources but at different times then, the overall capacity requirements remain fairly stable.

Identifying the optimal operating level

- The optimal operating level is the ideal level of operation at which the cost per unit is the lowest for the production unit.
- Larger or smaller volumes of output would result in higher unit cost.

4.7 Selecting from among the Alternative Sources of Capacity

Before selecting the best alternative from among the several alternative sources of capacity an organisation needs to examine or evaluate the alternatives for future capacity from several different perspectives.

The most important perspective is economic consideration. The questions to be answered are:

- Will an alternative be economically feasible?
- What would be the operating and maintenance cost?
- How soon it can be acquired?
- What would be the operating and maintenance cost?
- What would be its useful life?
- Would it be compatible with present personnel and present operating methods?
- What would be the public opinion or reaction to a new facility?

The capacity planning and facility planning decisions can be analysed by different approaches such as:

- Break-even analysis or cost volume analysis
- Financial analysis
- Decision analysis or decision tree analysis
- Waiting line analysis

These approaches are briefly discussed below;

Break-even Analysis

- It focuses on relationships between cost, revenue and volume of output
- His analysis facilitates estimation of profit under different operating conditions; it is particularly useful for comparing capacity alternatives
- This technique involves identification of all costs related to the production of a given product
- These costs are categorised as fixed costs and variable costs
- Fixed costs do not vary when volume of output changes. E.g. Rent, property tax, equipment cost, administrative costs, heating and air conditioning expenses etc
- Whereas variable costs vary with volume of output, e.g. material cost and labour costs

The total cost is equal to the sum of the fixed and variable cost per unit multiplied by the volume of output (q) the total revenue associated with a given volume of output Q is;

Total revenue = unit price x volume of output (Q)

The total profit is computed as,

Total profit (P) = Total revenue – volume of output (Q)

$P = TR - TC$

Where, TR = (Unit selling price) x volume of output

$TR = sQ$

Total cost (TC) = Fixed cost + (variable cost/unit x volume of output)

$TC = (FC + vQ)$ where v is the variable cost/unit

$P = TR - TC$

$P = (sQ) - (FC + vQ)$

$P = (s-v) Q - FC$

$Q = (P+FC)/((s-v))$

When total revenue equal total cost, (i.e. break-even point)

Total profit = Nil

Then, $QBEP = FC/((s-v))$

Assumptions

For cost volume analysis following assumptions to be made:

- One or a few products having the same cost characteristics are involved
- The volume of the product produced can be sold
- The variable cost per unit does not change with volume of output
- Fixed cost do not change when volume of output changes or they are set up changes
- The revenue per unit is the same regardless of volume sold
- Revenue per unit exceeds variable cost per unit

Financial Analysis

Financial analysis helps managers to take decisions regarding allocation of scarce funds to alternative investment proposals.

Two important terms used in financial analysis are:

a. Cash Flow

It refers to the difference between the cash received from sales and cash outflow for labor, materials, overhead and taxes etc.

b. Present Value

It is the sum of all future cash received from sales and cash flows of an investment proposed. The three most commonly used methods of financial analysis are:

- payback period method
- net present value method
- internal rate of return method

NOTE: A detailed discussion on Payback period, net present value, internal rate of return is beyond the scope of the syllabus.

Decision Theory/Decision Tree Analysis

- Decision analysis is helpful for financial comparison of alternatives under conditions of risk or uncertainty.
- A decision tree is a schematic model of the sequence of steps in a problem and the condition and consequences of each step.
- Decision trees are used in situations involving multiphase decisions and interdependent decisions as aids to managers who must see clearly what decisions must occur and the interdependence of the decision.
- Decision tree analysis provides
 - always structuring complex multiphase decisions,
 - a direct way of dealing with uncertain event and
 - an objective way of determining the relative value of each decision alternative
- The concept of expected value (EV) used in decision tree analysis gives only relative measures of value and not absolute measures.
- Decision tree analysis allows decision makers to see clearly what decision must be made, in what sequence they must occur, and their interdependence.

NOTE: A detailed discussion on Decision tree analysis is beyond the scope of the syllabus.

Waiting Line Analysis

Waiting line analysis or queuing theory is often used for designing of service system by determining the service capacity and expected cost for various levels of service capacity.

NOTE: A detailed discussion on Waiting Line analysis is beyond the scope of the syllabus.

4.8 Facility Location

- Plant location may be understood as the function determining where the plant should be located for maximum operating economy and effectiveness.
- The selection of a place for locating a plant is one of the problems, perhaps the most important, which is faced by an entrepreneur while launching new enterprise.
- A selection on pure economic considerations will ensure an easy and regular supply of raw materials, labour force, efficient plant layout, proper utilisation of production capacity and reduced cost of production.

The need for the selection of the location may arise under any of the following conditions:

- when the business is newly started
- the existing business unit has outgrown its original facilities and expansion is not possible, hence a new location has to be found
- the volume of business or the extent of market necessities the establishment of branches
- a lease expires and the landlord does not renew the lease
- when a company thinks that there is a possibility of reducing manufacturing cost by shifting from one location to another location and
- other social or economic reasons for instance, inadequate labour supply, shifting of the maker etc

4.9 Steps in Location Selection

To be systematic, in choosing a plant location, the entrepreneur would do well to proceed step by step, the steps being:

- Within the country or outside
- Selection of the region
- Selection of the locality or community
- Selection of the exact site

Domestic or International Location

- The 1st step in plant location is to decide whether the facility should be located domestically or internationally. A few years ago, this factor would have received little consideration. But with increasing internationalisation of business, the issue of home or foreign country is gaining greater relevance.
- If the management decides on foreign location the next logical step would be to decide upon a particular country for location. This is necessary because countries across the world varying with each other to attract foreign investments. The choice of particular country depends on such factors as political stability, export and import quotas, currency and exchange rates, cultural and economic peculiarities, and natural or physical conditions.

Selection of region

The selection of a particular region out of the many natural regions of a country is the second step of plant location.

The following factors influence such selection:

Availability of raw materials

As the manufacturing plant is engaged in the conversion of raw material into final product, it is essential that it should be located in a place where the supply of raw material with minimum transport cost.

Nearness to raw materials offers such advantages as:

- Reduced cost of transportation
- Regular and proper supply of materials uninterrupted by transportation breakdowns and
- Savings in the cost of storage of materials

Nearness to the market

Since the goods are produced for sale, it is very essential that the factory should be located near their market.

- A reduction in the cost of transporting finished goods to the market.
- The ability to adjust the production program to suit the likes and dislikes of consumers.
- The ability to render prompt service to the consumers, provide after sales services, and execute replacement orders without delay these are some of the advantages that accrue to the entrepreneur if he/she establish his / her factory near his market.
- Industries using pure or non-weight losing raw materials, industries producing perishable or bulky products and servicing units tend to be located near their market.

Availability of power

- Power is essential to move the wheels of an industry. Coal, electricity, oil and natural gas are the sources of power.
- Where coal is the source of power as in the case of the iron and steel industry, the factory has to be located near the coal fields.

Transport facilities

- While going with the process of selection of location an entrepreneur considers the question of the availability of transport facilities.
- Transport facilities are essential for bringing raw materials and men to the factory and for carrying the finished products from the factory to the market.
- A place which is well connected rail, road and water transport is ideal for a plant location.

Suitability of climate

- The climate has its own importance in the location of a plant because of two reasons.
- First there are certain industries which, because of the nature of their production, require particular climatic conditions. E.g. Humid climate for cotton textiles and jute.
- Secondly, climate affects labour efficiency. Extreme climatic conditions adversely affect labour efficiency and such places do not attract industries.

Government policy

- The influence of government policies and programs on plant location is apparent in every country, particularly in planned economies like ours.
- In the name of balanced regional development, many backward regions in India have been selected for the location of new industries, which would generate the region's economy and on larger canvas, the national economy.
- The government of India has been influencing plant location in a number of ways. Some of these are:
 - ⌚ Licensing policy
 - ⌚ Freight rate policy

- ① Establishing a unit in the public sector in remote area and developing it to attract other industries.
- ① Institutional finance and government subsidies.

Competition between States

- States compete with other to attract new industries. Various states offer investment subsidies and sales tax exemptions to new units.
- The incentives may not be of big help to big sized plants.
- But for small and medium sized plants the incentives do matter. The owners of these plants certainly consider incentive in selection of region.

Selection of community

Selecting a particular locality or community in a region is the third step in selection of plant location

The selection of a locality in a particular region is influenced by the following factors:

Availability of labour

Labour is an important factor in the production of goods. An adequacy of labour supply at reasonable wages is very essential for the smooth and successful working of an organisation.

Civic amenities for workers

Besides good working conditions inside the factory, the employees require certain facilities outside it. Recreation facilities such as clubs, theatres, parks, must be provided for the employees. They require schools for their children.

A place which abounds in all these facilities will naturally be preferred to another place which lacks them.

Existence of complimentary and competing industries

The existence of complementary industries is favorable to the location of industries, because an industrial unit, in association with other units, can get the following benefits:

- An industrial unit, in collaboration with other similar units, can secure materials on better terms than it can do it by itself.
- The concentration of similar industries at one place improves the labor market both for the employer and employee.
- The specialised centers, bank, become familiar with the requirements of the industry, this makes the granting of loans easy
- The group of plants will attract a variety of repair plants, such as foundries, machine, shops, tool makers and the like.
- The reputation build up by the existing units will be shared by the new units established in the same e. locality.

Finance and research facilities

Adequate capital is essential for the successful working of any organisation. A place where facilities for raising capital are available attracts new industries. This is particularly true in developing countries, where capital is not available uniformly throughout the country. In advanced countries the case is different because, in such countries, capital is distributed uniformly.

Availability of water and fire fighting facilities

Some industries require a plentiful supply of water for their working. Some of these are fertiliser units, rayon manufacturing units, absorbent cotton manufacturing units, leather tanneries, bleaching, dyeing and screen printing units. These factories must be located in places where water is available in abundance. Water may be obtained from the local authority, from the canal, from a river or a lake, or by sinking a borewell. In any case, the supply of water should be considered with respect to its regularity, cost and purity.

Local taxes and restrictions

Local authorities collect charges for the supply of water, electricity and other facilities. They also collect various taxes from industrial units. They impose restrictions on the location of new units in the public interest. It is natural, therefore for industrialists to prefer an area where such taxes and restrictions are the least tedious

Personal factors

There are entrepreneurs, especially small industrialists, who locate their plants purely on personal grounds disregarding economic considerations.

Such locations sometimes may totally disapprove the current theories of plant location.

Selection of Site

The selection of an exact site in a chosen locality is the fourth step in plant location. The selection of the site is influenced by the following considerations:

Soil, size and topography

- For factories producing engineering goods, the fertility or otherwise of the soil may not be a factor influencing plant location. But for agro-based industries, a fertile soil is necessary for ensuring a strategic plant location.
- The area of the land should be such as to accommodate not only the existing manufacturing facilities, but offer scope for future expansion programs as well.
- Besides the area, the cost of land deserves consideration. If the land is to be purchased, and if the place enjoys all the facilities for plant location, its price should not affect the decision to locate the plant in that particular place, because the cost of land forms a small percentage of the total fixed investment.
- But if the land is to be leased, the question of rent, rates and taxes has to be seriously considered because they constitute a part of the permanent working expenses.
- The topography of the place deserves consideration to some extent. A hilly, rocky and rough terrain is unsuitable for plant location because a great deal of expenditure has to be incurred to level it.

Disposal of waste

The site selection for the location of the plant should have the provision for the disposal of the waste. There must be enough land for dumping of the solid waste.

The site selected should, as far as possible, be in the midst of good scenery. The question of beauty should not be ignored.

4.10 Errors in Selection

Though location selection is relatively easy, businessmen commit errors and wrong locations are selected. Interestingly, errors in site selection seem to fall into a pattern.

Some of the most common errors are:

- lack of investigation
- personal likes and dislikes
- reluctance of key executives to move from traditional established home ground to new and better locations
- moving to congested areas already or about to be over industrialised

- preference for acquiring an existing structure that is improperly located or not designed for the most efficient production
- choice of community with low cultural and educational standards

4.11 Importance of Location Factors

The site selected may be an urban, a suburban or a rural one. All these offer advantages as industrial sites.

Rural site

The facilities available at a village site are not as many as are found in a city; but they are more attractive.

- Land is available at cheaper rates.
- The rates and taxes are negligible.
- Spacious layout available and open spaces are possible.
- Advantages of single storey buildings are available.
- Low wages for unskilled workers but high wages for skilled workers because they have to be mobilised from elsewhere.
- Fewer labour troubles
- Avoidance of danger from fire and other hazards resulting from the operations of neighboring units
- Avoidance of undesirable neighbors
- Lack of supply of skilled workers
- Lack of civic amenities for employees
- Lack of transport facilities

Suburban site

- They are less costly.
- All transport facilities are available.
- Quarters for workers provided by local authorities or by private entrepreneurs.
- Easy availability of labors.
- Land is available at cheap rates.

Urban site

A big city has all the facilities which favor a location for a plant.

- Transportation facilities are no problem.
- Labour is available in plenty.
- Municipal services for water, sewage disposal, public health and education are available.
- banking, repair and related services are available
- facilities for contracting out a portion of the work are available
- a large local market is available
- high advertising value is available

4.12 Location Models

Various models are available which help identify a near ideal location. The most popular models are:

Factor rating method

In this method, factor ratings are used to evaluate alternative locations. The method has the following advantages:

- Simplicity which facilitates communication about why one location/site is better than another.
- Enables bringing diverse locational consideration into the evaluation process.
- Foster consistency of judgment about location alternatives.

Point rating method

In selecting a site or location companies have several objectives, but not all are of equal importance. The relative weight a company assigns to each objective or to each location factor may be represented by the number of points a perfect site would receive in each category. Each potential site is then evaluated with respect to every factor a company is looking for and points are assigned for each factor. The site with the highest total number of points is considered superior to other sites.

Break even analysis

In comparing several potential locations on an economic basis, the only revenues and costs that need to be considered are the ones that vary from one location to another. If revenue per unit is the same regardless of where the good is produced, the total revenues can be eliminated from consideration. An economic comparison of locations can be made by identifying the fixed costs and variable costs and plotting the break even-analysis on a graph for each location.

The graphical approach can easily identify the range of annual production volume over which a location is preferable. The steps involved in this method are:

- Determine all relevant costs that vary with each location.
- Categorise the costs for each location into annual fixed costs (FC) and variable cost per annum (VC), for each location.
- Plot the total cost associated with each location on a single chart or graph of annual cost versus annual production volume.
- Select the location with the lowest total annual cost (TC) at the expected production volume per annum (Q)

Qualitative Factor Analysis

If economic criteria are not sufficiently influential to decide the location alternative; a system of weighting the criteria might be useful in making a plant location decision. This approach is referred to as qualitative factor analysis. The steps involved are:

- Develop a list of relevant factors.
- Assign a weight to each factor to indicate its relative importance.
- Assign a common scale to each factor and designated any minimum point to be scored by any location.
- Score each potential location according to the designated scale and multiply the scores by the weights to arrive at the weighted scores.
- Total the points for each location, and choose the location with the maximum points.

Summary

- Capacity plans are made at two levels.
- Capacity planning is central to the long term success of an organisation.
- Capacity planning is generally viewed in terms of three time horizons or durations;
- Long range capacity planning which is usually having a time horizon of more than one or two years.
- Intermediate range capacity planning which has a time horizon or duration for the next 6-18 months. The intermediate range capacity may be varied by such alternatives such as hiring or laying off labour, purchasing or making new tools and minor equipments and outsourcing/subcontracting etc.
- Short range planning which has a time horizon or duration of less than one month. This is concerned with day to day planning such as daily scheduling of activities and machine loading or weekly scheduling process which involves making adjustments to eliminate the variance between planned output and actual output.
- Many decisions about design of the production system and operation of the production system may have an impact on capacity.
- To enhance capacity management, the following approaches to capacity alternatives could be developed:
- To be systematic, in choosing a plant location, the entrepreneur would do well to proceed step by step, the steps being:

Self Assessment

1. _____ capacity planning which is usually having a time horizon of more than one or two years.
 - a. Short range
 - b. Intermediate range
 - c. Long range
 - d. Medium range

2. Intermediate range capacity planning which has a time horizon or duration for _____ months.
 - a. 10-12
 - b. 6-8
 - c. 10-20
 - d. 6-18

3. _____ capacity refers to the maximum output that can possibly be attained.
 - a. Production
 - b. Design
 - c. Effective
 - d. Efficient

4. The capacity is measured relative to equipment is known as _____.
 - a. Peak Capacity
 - b. Relative Capacity
 - c. Design Capacity
 - d. Measure of Capacity

5. Effective capacity is usually less than _____ capacity because of capacity losses due to realities such as productmix changes, need for periodic preventive maintenance of equipment, problems in scheduling and balancing operations, coffee breaks, lunch breaks and so on.
 - a. peak
 - b. relative
 - c. design
 - d. measure of

6. Following analysis focuses on relationships between cost, revenue and volume of output is known as _____.
 - a. financial analysis
 - b. break-even analysis
 - c. decision tree analysis
 - d. waiting line analysis

7. Which of the following analysis helps managers to take decisions regarding allocation of scarce funds to alternative investment proposals?
 - a. Financial analysis
 - b. Break-even analysis
 - c. Decision tree analysis
 - d. Waiting line analysis

8. The difference between the cash received from sales and cash outflow for labor, materials, overhead and taxes etc. is known as_____.
- Present value
 - Cash inflow
 - Cash flow
 - Interest
9. The expected value (EV) gives only relative measures of value and lot absolute measures is used in_____.
- Waiting line analysis
 - Decision tree analysis
 - Financial analysis
 - Break-even analysis
10. Adequate_____is essential for the successful working of any organisation, where facilities for raising capital are available attracts new industries.
- machinery
 - manpower
 - money
 - materials

Chapter V

Facility Layout

Aim

The aim of this chapter is to:

- introduce the concept of facility layout
- discuss the importance of facility layout
- explain different types of layout

Objectives

The objectives of this chapter are to:

- explain the importance of facility layout in operations management
- comprehend the meaning of facility layout
- enlist the steps involved in facility layout

Learning outcome

At the end of this chapter, you will be able to:

- identify the steps in designing layout
- understand the problems of facility layout
- understand the inputs of layout

5.1 Introduction to Facility Layout

A typical manufacturing plant has a number of diverse activities interacting with each other. Thus, raw materials arrive at a shipping dock, they are unpacked and checked in quality control area, then they might be processed through several processing areas, and finally the finished product again passes through the shipping dock.

- In addition to areas specifically related to production, there must be dressing rooms, lunch rooms, and restrooms for employees; offices for supervision, design, and production control; and space for inventory and aisles.
- In fact, a plant might be viewed as a large number of finite geometric areas arranged on the floor space of the building.
- The problem of arranging these areas in an effective manner is the facility layout problem.
- Clearly, the layout problem has relevance in many areas of facility and equipment design, from the layout of the rooms in a home to the layout of chips on an electronic circuit board.
- Although the facility layout problem may arise in many contexts, in this section we assume we are dealing with a plant manufacturing products for sale.

5.2 Inputs of the Layout

Layout decisions entail determining the placement of departments, work groups within the departments, workstations, machines, and stock-holding points within a production facility.

The objective is to arrange these elements in a way that ensures a smooth work flow (in a factory) or a particular traffic pattern (in a service organisation).

In general, the inputs to the layout decision are as follows:

- Specification of the objectives and corresponding criteria to be used to evaluate the design.
- The amount of space required, and the distance that must be travelled between elements in the layout, are common basic criteria.
- Estimates of product or service demand on the system.
- Processing requirements in terms of number of operations and amount of flow between the elements in the layout. Space requirements for the elements in the layout.
- Space availability within the facility itself, or if this is a new facility, possible building configurations.

5.3 Types of Layout

Several alternative layout types are appropriate for different product mixes and production volumes. Determination of the layout type is a major design decision because it affects so many other aspects of the production system.

The formats by which departments are arranged in a facility are defined by the general pattern of work flow; there are four basic types:

Process Layout/ Job Shop Layout

A process layout (also called a job-shop or functional layout) is a format in which similar equipment or functions are grouped together, such as all lathes in one area and all stamping machines in another.

- A part being worked on then travels, according to the established sequence of operations, from area to area, where the proper machines are located for each operation.
- This type of layout is typical of hospitals, for example, where areas are dedicated to particular types of medical care, such as maternity wards and intensive care units.
- In the Job Shop Layout, machines are grouped according to function into machine centers. Orders for individual products are routed through the various machine centers to obtain the required processing.

- This layout may be appropriate when there are many different products, each with a low volume of production. Machines are general purpose, within their general function area, so that a wide variety of products can be handled. Because the expense of automation may be too great to be justified by the low volume, the machines in this arrangement will probably be at a relatively low level of automation. Workers will be highly skilled.
- Production scheduling is difficult with this type of arrangement because the level and type of work is highly variable.
- This results in large amounts of work-in-process, long product lead times, and high levels of management interaction.
- Typically there is a high degree of product movement required by the long and variable routes of individual products through the system.
- The costs for setting up machines to produce the various products will be high because of the variety of different products and small lot sizes.
- The arrangement can adapt readily to changes in product volume and design because of its inherent flexibility

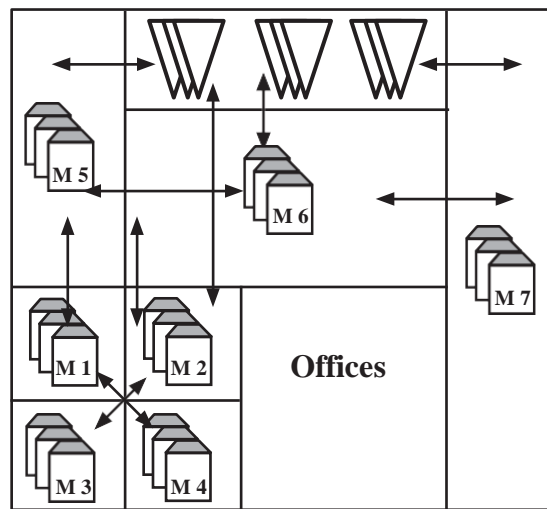

Fig. 5.1 Job shop layout

Product Layout/ Flow Shop Layout

- A product layout (also called a flow-shop layout) is one in which equipment or work processes are arranged according to the progressive steps by which the product is made.
- The path for each part is, in effect, a straight line. Production lines for shoes, chemical plants, and car washes are all product layouts.
- Here the product (or products) follows a fixed path through the production resources. The resources are arranged to minimise the material movement required.
- This type of layout is typical for an assembly line where a single product, or a few very similar products, passes through the line in a continuous fashion. Because of the high volume of production, the machines on the line can be designed with a high level of fixed automation, with very little manual labour.
- Direct labour will be much less than for the job shop, but there will be high costs for maintenance. Setup costs and work in progress will be low for this arrangement.
- The line, in general, is not flexible to product or volume changes. It is very sensitive to failures that cause the entire line to shut down.
- The arrangement is also appropriate for a flow shop that may have a number of products that all pass through the machine centres in the same order.
- In this case, the machines implementing the system may or may not be automated depending on the product mix and volume, but one would expect a higher level of automation than for the job shop.

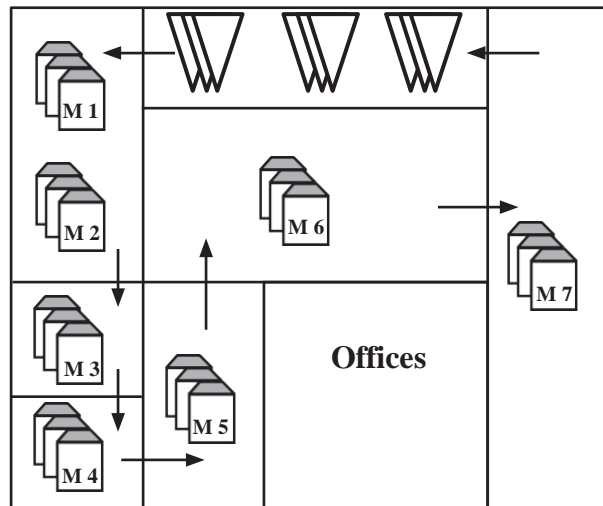

Fig. 5.2 Flow shop layout

Group Technology Layout

- A group technology (cellular) layout groups dissimilar machines into work centers (or cells) to work on products that have similar shapes and processing requirements.
- A group technology (GT) layout is similar to a process layout in that cells are designed to perform a specific set of processes, and it is similar to a product layout in that the cells are dedicated to a limited range of products.
- Group technology also refers to the parts classification and coding system used to specify machine types that go into a cell. The product mix appropriate for this arrangement is similar to that of the job shop.
- Products are grouped into classes that have some similarity with respect to processing. A manufacturing cell is designed for each group consisting of machines particularly adapted to the processing required.
- The figure shows the cells as collections of dissimilar machines. Because the range of products manufactured by each cell is less than that for the job shop, the machines and workers can be more specialised.
- Typically, the workers in a cell are given more of the responsibility for production scheduling of a product class. This, together with the start-to-finish nature of the processing, results in more interesting jobs for the workers.
- The group technology arrangement requires less setup time and cost than the job shop because of the greater specialisation of function.
- It is compatible with the just-in-time concept of manufacture, so prevalent today, because of the smaller lot sizes made possible by the low setup costs.
- Often the level of automation with group technology is low, indicating the dependence of the concept on the skill of the labour force.
- Many companies have, however, introduced highly automated flexible manufacturing cells into the system. Because the cell has a smaller range of products than the entire plant, it is easier to design the automation to handle the set of products in a group.
- The group technology approach is more sensitive to changes in product mix and volume than the job shop, again because of the specialisation introduced because of the manufacturing cell approach. When a product requires processing in more than one cell, problems similar to those of the job shop are introduced.

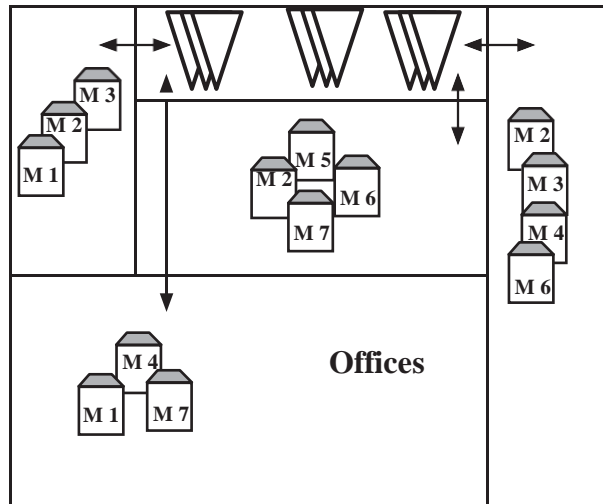

Fig. 5.3 Group technology layout

Fixed Position Layout

- In a fixed-position layout, the product (by virtue of its bulk or weight) remains at one location. Manufacturing equipment is moved to the product rather than vice versa. Construction sites and movie lots are examples of this format.
- For tasks on large objects such as the manufacture of an electrical generator, the construction of a building, or the repair of a large airplane, the machines implementing the operation must come to the product, rather than the product moving to the machines.
- Here the question is more often the scheduling of operations rather than the layout of machines.
- A relatively low number of production units in comparison with process and product layout formats characterises fixed-position layout.
- In developing a fixed-position layout, visualise the product as the hub of a wheel with materials and equipment arranged concentrically around the production point in their order of use and movement difficulty.
- Thus, in building custom yachts, for example, rivets that are used throughout construction would be placed close to or in the hull; heavy engine parts, which must travel to the hull only once, would be placed at a more distant location; and cranes would be set up close to the hull because of their constant use.
- In fixed-position layout, a high degree of task ordering is common, and to the extent that this precedence determines production stages, a fixed-position layout might be developed by arranging materials according to their technological priority.
- This procedure would be expected in making a layout for a large machine tool, such as a stamping machine, where manufacture follows a rigid sequence; assembly is performed from the ground up, with parts being added to the base in almost a building-block fashion.

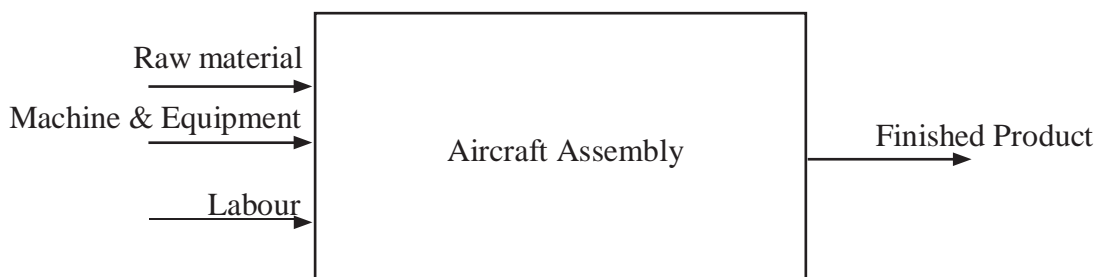

Fig. 5.4 Fixed position layout

Flexible Manufacturing System

- The FMS is a system with automated material handling moving individual units of product between automated processors. Robotic manipulators often handle material.
- Using computer controlled movement and processing, a wide variety of products can be manufactured. All of this is to be accomplished with very low setup time, great flexibility of function, and very little manual labor.
- The diversity of possible FMS, and the rapidly changing technologies, makes detailed consideration of the design of FMS beyond the scope of this text.
- Certainly many of the classical questions (and answers) associated with facility design are no longer relevant for the FMS. In this text, we consider the FMS as just another kind of machine, with perhaps a very broad range of capabilities.

5.4 Layout Design Procedure

Designing of layout of a plant is a specialised activity and should be carried out systematically.

The various steps to be followed in the layout design are:

- Statement of specific objective
- Collection of basic data on sales
- Preparation of various kinds of charts, such as flow charts, flow diagrams, templates etc
- Designing the production process
- Planning material flow pattern
- Planning individual work centers
- Selection of materials handling equipments
- Planning of auxiliary and service facilities
- Determination of routing, space requirements for each work station, service department, employee facility etc
- Draw building specifications to fit the requirements of layout
- Preparation of floor plan indicating location of doors, windows, stair case, lifts etc
- Preparation of tentative or draft layout plans
- Preparation of detailed layout drawing and get approval of top management
- Preparation of work schedule for the installation of layout

5.5 Layout Problem

- The layout problem is to arrange the physical spaces required for several departments in a given space provided for the departments.
- In practice the facility layout problem is often solved by intuition, using the artistic and spatial skills of the human designer; however, when there are quantitative considerations associated with the layout problem, the human is at a disadvantage as compared to the computer.
- In this chapter we concentrate on computerised procedures for solving the layout problem. There are a variety of problems regarding layout one might encounter. In this section we explain the problem by specifying the data and describing the decisions.

Input data

- Here we are considering the problem of arranging several departments on a plant with a single floor and fixed dimensions.
- Certain data is necessary to describe the layout problem.
- Number of departments, n , Physical area of each department, A_i for $i = 1 \dots n$
- Physical dimensions of the plant in which the departments are to be placed: Length, L , and Width, W .

- Product flow between every pair of departments: f_{ij} for $i = 1 \dots n$ and $j = 1 \dots n$.
- Material handling cost between every pair of departments measured in dollars per unit-foot: c_{ij} for $i = 1 \dots n$ and $j = 1 \dots n$.

Distance

- Our models involve the distance from one department to another. The distance depends on the layout. To illustrate consider a problem with ten departments with each department having an area of 100 square feet.
- The ten departments are to be placed in an area that is 50 feet long by 20 feet wide. One layout is shown in figure below.

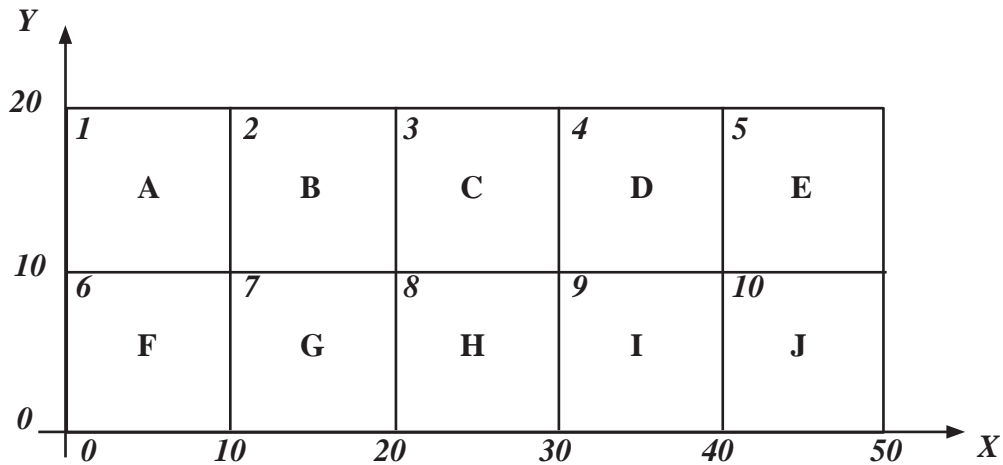

Fig. 5.5 A layout of departments

- This is only one of many possible layouts. If we assume that the departments must maintain a square shape, every permutation of the letters A through J is a different layout. There are $n!$ Permutations.
- The matrix as in Fig. 5.6 describes the flow between the departments. This is called the From-To matrix because an element (i, j) contains f_{ij} , the flow from department i to department j

From \ To	A	B	C	D	E	F	G	H	I	J
A					5				1	9
B				3	4		1			
C				1			9			2
D							6		1	
E						8	3			
F							2	5		
G								6		
H									8	
I										
J										

Fig. 5.6 From to matrix for the office example

- The criterion for the layout problem involves the distance between departments. First we must prescribe the end points for the distance measurement.
- Here we assume that distances are measured between the centroids or centers of gravity of departments. Second, we must specify the route of travel. One possibility is that flow will follow a straight-line path. This is the Euclidean measure. More common in layout analysis, is to assume that flow travels via paths that are parallel to the axes of the layout. This is the rectilinear measure.
- The centroids are specified in terms of the coordinate system as, $x(i) = x$ -coordinate of the centroid of department i , and $y(i) = y$ -coordinate of the centroid of department i .
- The centroid is the same as the center of the area when the department is rectangular. For a more general shape, the centroid is the center of gravity of area.
- In the example case of Fig. 1 we have the centroids as follows.

Department A: $x(A) = 5, y(A) = 15$.

Department B: $x(B) = 15, y(B) = 15$.

Department C: $x(C) = 25, y(C) = 15$.etc.

The distance between two departments by a rectilinear measure is

$$d_{ij} = |x(i) - x(j)| + |y(i) - y(j)|.$$

- Here the vertical lines indicate absolute value. Fig. 5.7 shows both the flow and distance between all pairs of departments on the from-to chart.
- The flow appears above the diagonals and the distance appears below.

From \ To	A	B	C	D	E	F	G	H	I	J	Sum
A					5 40				1 40	9 50	690
B			3 20	4 30		1 10					190
C				1 10		9 20				2 30	250
D						6 30		1 10			190
E						8 50	3 40				520
F							2 10	5 20			120
G								6 10			60
H									8 10		80
I											0
J											0

Fig. 5.7 Computation of the total distance travelled

Criterion for comparison

- The flow multiplied by the distance and summed over all cells of the chart. We compute the cost for the flow from i to j as the product of the material handling cost, the flow and the distance between the departments.
- The cost of the layout is the sum of the flow cost.

$n \times n$

$$z = \sum_{i=1}^n \left[\sum_{j=1}^n c_{ij} f_{ij} d_{ij} \right]$$

$i=1 \quad j=1$

- The cost associated with each row of the chart is shown at the right of Fig. 5.7. The cost of the layout is the sum of the row costs.
- The factors c_{ij} and f_{ij} are given as data, but the factor d_{ij} depends on the layout.

5.6 Importance of Facility Layout

The importance of layout would be better appreciated if one understands the influence of an efficient layout on the manufacturing function; it makes it smooth and efficient.

- Good layout helps to manufacture quality goods in less manufacturing cost.
- Long distance movements should be avoided and irrelevant operations are eliminated.
- Full utilisation of area and work force.
- It minimises the lead time and production delays.
- It helps to improve quality control and inspection.
- Investment on equipment can be minimised by planned machine balanced and location.
- It helps in better production control and easy supervision.
- Ultimately all above factors will improve the employee morale, which depends on working conditions, employee facilities, reduced number of accidents and increased earnings.

Summary

- The formats by which departments are arranged in a facility are defined by the general pattern of work flow; there are three basic types (process layout, product layout, and fixed-position layout) and one hybrid type (group technology or cellular layout).
- A process layout (also called a job-shop or functional layout) is a format in which similar equipment or functions are grouped together, such as all lathes in one area and all stamping machines in another.
- A part being worked on then travels, according to the established sequence of operations, from area to area, where the proper machines are located for each operation. This type of layout is typical of hospitals, for example, where areas are dedicated to particular types of medical care, such as maternity wards and intensive care units.
- A product layout (also called a flow-shop layout) is one in which equipment or work processes are arranged according to the progressive steps by which the product is made. The path for each part is, in effect, a straight line. Production lines for shoes, chemical plants, and car washes are all product layouts.
- A group technology (cellular) layout groups dissimilar machines into work centers (or cells) to work on products that have similar shapes and processing requirements. A group technology (GT) layout is similar to a process layout in that cells are designed to perform a specific set of processes, and it is similar to a product layout in that the cells are dedicated to a limited range of products. (Group technology also refers to the parts classification.
- Coding system used to specify machine types that go into a cell.) In a fixed-position layout, the product (by virtue of its bulk or weight) remains at one location. Manufacturing equipment is moved to the product rather than vice versa.
- Construction sites and movie lots are examples of this format. Many manufacturing facilities present a combination of two layout types. For example, a given production area may be laid out by process, while another area may be laid out by product. It is also common to find an entire plant arranged according to product layout.
- Different types of layouts may be used in each area, with a process layout used in fabrication, group technology in subassembly, and a product layout used in final assembly.
- Facility layout is where the rubber meets the road in the design and operation of a production system. A good factory (or office) layout can provide real competitive advantage by facilitating material and information flow processes. It can also enhance employees' work life.

Self Assessment

1. The problem of arranging floor space of the building, restrooms for employees; offices for supervision, design, and production control and space for inventory etc. is known as _____.
 - a. inventory problem
 - b. layout conflict
 - c. facility layout problem
 - d. facility design problem

2. _____ is a format in which similar equipment or functions are grouped together, such as all lathes in one area and all stamping machines in another.
 - a. Flow shop layout
 - b. Job shop layout
 - c. Fixed position layout
 - d. Group technology layout

3. _____ type of layout is typical for an assembly line where a single product, or a few very similar products, passes through the line in a continuous fashion.
 - a. Job shop layout
 - b. Fixed position layout
 - c. Flow shop layout
 - d. Group technology layout

4. _____ also refers to the parts classification and coding system used to specify machine types that go into a cell.
 - a. Group technology layout
 - b. Job shop layout
 - c. Fixed position layout
 - d. Flow shop layout

5. In _____ layout, a high degree of task ordering is common, and to the extent that this precedence determines production stages, a fixed-position layout might be developed by arranging materials according to their technological priority.
 - a. Job shop
 - b. Fixed position
 - c. Flow shop
 - d. Group technology

6. Which of the following system is a system with automated material handling moving individual units of product between automated processors?
 - a. Assembly line system
 - b. Robotic system
 - c. Flexible Manufacturing system
 - d. MRP

7. Good Facility Layout helps to manufacture quality goods in_____.
 - a. economical manufacturing cost
 - b. less manufacturing cost
 - c. average manufacturing cost
 - d. controlled manufacturing cost

8. Production scheduling is difficult with this type of arrangement because the level and type of work is highly variable.
 - a. Fixed-position layout
 - b. Group technology layout
 - c. Product layout
 - d. Process layout

9. Which of the following layout is similar to process layout?
 - a. Fixed-position layout
 - b. Group technology layout
 - c. Product layout
 - d. Process layout

10. Construction sites and movie lots are examples of the following format of layout.
 - a. Product layout
 - b. Process layout
 - c. Group technology layout
 - d. Fixed-position layout

Chapter VI

Work System Design

Aim

The aim of this chapter is to:

- introduce the design of work system in manufacturing and service operations
- explain motion study
- define work study and know its benefits

Objectives

The objectives of this chapter are to:

- enlist the steps involved in basic work study procedure
- explain job design and factors affecting it
- explicate the design of work system

Learning outcome

At the end of this chapter, you will be able to:

- understand the work measurement techniques
- comprehend the importance of time measurement in work design
- understand the importance of job design and work allocation

6.1 Introduction

Work systems are systems in which humans, computer, robotic and other systems, artifacts and space come together performing activities over time to produce goods, services or, as is the case in the work system described in this paper, scientific discovery.

The work systems we encounter everyday have mostly existed over a long period of time. Improvement of such work systems is often done through business process analysis and reengineering (Hammer and Champy, 1993) (Davenport, 1993).

- Design of work systems is an important component in Production and Operations Management.
- Design of work systems forms the basis and explains the importance of work design.
- Design of work systems is used to describe the two basic approaches to job design, the first approach focuses on
- Efficiency through job specialisation and the other focuses behavioral approaches to job design.

Design of Work System also entails method analysis which in turn centers on how jobs are performed. Motivation and Trust also form an important dimension in Design of Work systems as this alone provides an opportunity to the Organisation to develop effective teams who can achieve organisation short and long term objectives.

Motivation and Trust observations also emphasises working conditions that in turn lead to work measurements which leads to reward and compensation of the individual working for the organisation.

6.2 Design of Work System

Work System Design consists of job design, work measurement and establishment of time standards and worker compensation.

- The interesting fact is that even in decisions in other areas of design can affect the work design system or even a change in the work design system can change the decisions in other areas.
- Like Product or Service, design will affect Design of Work Systems. Layout Decisions will also affect Design of Systems.
- It is thus logical to ensure that SYSTEMS approach is followed in a decision for DESIGN, so a decision in one part of the system is equally replicated and acceptable to all the system.
- For example, Product or Service Design would require proper people with standardised job description.

6.3 Different Terminologies in Work Design System

Following are the different terminologies in work design system

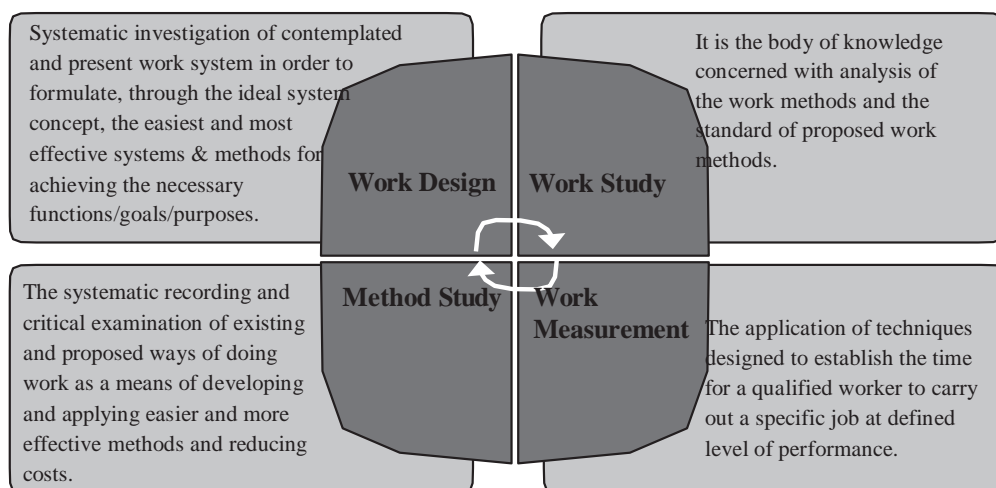

Fig. 6.1 Terminologies in work design system

6.4 Job Design

Job design involves specifying the content and methods of job. In general the goal of the job design is to create a work system that is not only productive but also efficient.

Job designers are concerned with:

- What will be done?
- Who will do the job?
- How the job will be done?
- Where the job will be done ergonomics?

A successful Job Design must have the following qualities:

- carried out by experienced personnel who have the necessary training and background
- consistent with the goals of the organisation in documented form understood and agreed by both management and employees shared with the new employees

6.4.1 Factors that Affect Job Design

Following are the factors that affect job design

- Lack of knowledge of the employees
- Lack of management support
- Lack of documented job design which often leads to poor audit review and referral
- Job design can be carried out in 2 ways the efficient school and the behavior school
- Efficiency school was popular in 1950s based on frederick w taylor's scientific management principles
- Behavior school is relatively new concept and focused on ways to eliminate workers dissatisfaction and incorporate the feeling of control in work

6.5 Design of Work Systems

Design of work system focuses on following points:

Specialisation

The term specialisation refers to work that concentrates on some aspect of a product or service. Jobs that have a narrow scope such as Assembly lines, medical specialties, MBA courses etc. Specialisation in jobs tends to yield high productivity, low unit costs and lead to high standard of living in most of the industrial nations.

Behavioral Approaches to Job Design

In order to make jobs more interesting and meaningful job designers often consider Job Enlargement, Job Rotation and Job Enrichment.

- Job Enlargement relates to giving a worker a larger portion of the total task by horizontal loading.
- Job Rotation pertains to Workers periodically exchange jobs.
- Job Enrichment is increasing responsibility for planning and coordination tasks, by vertical loading

Motivation

The importance of these approaches to job design is that they have the potential to increase the motivational power of jobs by increasing worker satisfaction through improvement in quality of work life.

Motivation always influences quality and productivity. It contributes to work environment where as Trust influences productivity and employee-management relations

Teams

Organisations adopt teams in order to exploit the benefits of teams:

- Higher quality
- Higher productivity
- Greater worker satisfaction
- Self-directed teams are groups of empowered to make certain changes in their work process.

Methods Analysis

Methods analysis deals with analysing how a job gets done, begins with overall analysis and then moves to specific details like changes in tools and equipment, Changes in product design or new products, Changes in materials or procedures and other factors (e.g. accidents, quality problems).

Methods Analysis Procedure is simple and effective and does the following:

- Identifies the operation to be studied
- Gets employee input
- Studies and documents the current method
- Analyses the job
- Proposes new methods
- Installs new methods
- Follow-ups to ensure improvements have been achieved
- Selecting operations to study
- Sometimes a supervisor or a foreman may request an operations or part of the operations to be studied. This would be the intent to increase productivity and reduce costs.

The guidelines for studying a job would include

- A high labor content
- Repeated frequently
- Unsafe, tiring, unpleasant, noisy and environmentally poor
- Quality problems, scheduling bottlenecks etc
- Analysing the job and proposing new methods
- Job design analyst should question the integrity and effectiveness of present and proposed methods

One should use charts, graphs and verbal descriptions to capture how the job is being performed. This can be the first basis and can lead to improvement in job design.

Flow process chart

- Chart used to examine the overall sequence of an operation by focusing on movements of the operator or flow of materials
- Flow process chart includes worker-machine chart
- Chart used to determine portions of a work cycle during which an operator and equipment are busy or idle

Experienced Job design analysts often develop a checklist and try to answer these questions

- Why is there a delay or storage at this point?
- How can travel distances be shortened?
- Can material handlings be reduced?
- Would a rearrangement of the workplace result in greater efficiency?

- Can similar activities be grouped?
- Would the use of additional or improved equipment be helpful?
- Does the worker have any suggestion or recommendation for improvement?

Installing the improved method

- Successful implementation of the proposed method changes requires convincing management of the desirability of the new method and obtaining the cooperation of the worker
- If the worker has been consulted than the task of installing the new method is easier otherwise it can become the toughest part
- If there is a paradigm change (major change or new method) from the old method, the implementation makes take a longer time follow up is required to ensure that the changes have been incorporated

Motion Study

Motion Study is the systematic study of the human motions used to perform an operation. The purpose is to eliminate /weed-out unnecessary motions and identify the best sequence of operations for maximum efficiency. Motion study forms an important part in productivity improvements. It is based on Frank Gilbreth's brick laying trade in the early 20th century, with time motion study techniques.

Motion Study Techniques often incorporate the following four types:

- Motion study principles – guidelines for designing motion-efficient work procedures
- Analysis of therbligs – basic elemental motions into which a job can be broken down
- Micro motion study -use of motion pictures and slow motion to study motions that otherwise would be too rapid to analyse charts

Motion Study Principles

Gilberth's work laid the foundation for motion study principles, which are guidelines for designing motion efficient work procedures.

The guidelines are divided into three categories.

- Principles of the use of body
- Principles for the arrangement of the work place
- Principles for the designs of tools and equipments

Developing work methods An operations manager along with an analyst aims for motion efficiency by achieving the following

- Elimination of unnecessary motions
- Combination of various activities
- Reduction in fatigue
- Improvement in the arrangement of the workplace
- Improvement in the design of tools and equipment

Analysis of Therbligs

Basic elemental motions into which a job can be broken down into following:

- Search implies hunting for an item with eyes or hands
- Select means to choose from a group of objects
- Grasp means to take hold of the object
- Hold refers to retention of an object that has been grasped Therblig techniques

- Transport load means movement of an object after hold Release load means to deposit the object.
- Some other common therbligs are inspect, position, plan, rest and delay.
- Also frank and lillian gilbreth are responsible for micro motion study.

Working Conditions

- Work Measurement determines how long it should take to do a job.
- This may be focusing on an individual's performance or completion of a mega scale project.
- When we discuss the design part of work systems we often discuss the importance of standard time in work measurement.
- Standard time is Production and Operations Management –MGT613 VU the amount of time it should take a qualified worker to complete a specified task, working at sustainable rate, using given methods, tools and equipments, raw materials and work place arrangements.

It also employs the following common types of work measurement techniques

- Stopwatch time study
- Predetermined data

Stopwatch time study

Stopwatch time study is used to develop a time standard based on observations of one worker taken over number of cycles. That is then applied to work of others of the same organisation who perform the same work.

The basic steps in stop watch time study include:

- Define the task to be studied and inform the workers who be studied
- Determine the number of cycles to observe
- Time the job and rate the workers performance
- Compute the standard time

Also, the number of cycles that must be timed is a function of three things:

- The variability of observed times
- The desired accuracy
- The desired level of confidence interval for the estimated job time

Desired accuracy is expressed as percentage of the mean of the Observed Time. $N = (z_s/a \times \bar{x})^2$

Where Z is the number of normal standard deviations needed for desired confidence S is sample standard deviation a is desired accuracy percentage \bar{x} is the sample mean

Example

Q. A Mechanical Engineer working for an automobile manufacture in Lahore presents the following information to the Operations Manager. The assembly workers take a mean time of 120 minutes to assemble a single car with a standard deviation of 5 minutes. The confidence limit if 95%, The Operations Manager will need how many observations if the desired maximum error is + 5% Solution

Solution:

Given Data S= 5 minutes, Z is 1.96 (since 95 CI) \bar{x} = 120 minutes, a= 5 % The formula is,

$$N = (z_s/a \times \bar{x})^2$$

Substituting the values,

$$N = ((1.96)(5)/(0.05)(120))^2 = (96.04)/(36) = 2.67 \text{ studies} = 3 \text{ studies}$$

Development of a time standard

- Development of a Time standard involves Observed Time (OT), Normal Time (NT) and Standard Time (ST).
- Mathematically Observed Time OT is represented by $OT = \sum X/n$
- Observed Time OT is just the average of the recorded times.
- Also Normal Time NT is the observed time adjusted for worker performance.
- Similarly, Normal time $NT=OT \times PR$
- Computed by multiplying observed time with Performance rating. Normal time is the length of time a worker should take to perform a job.
- Another important concept is Standard time.
- Standard Time = $ST=NT \times AF$ is the normal time plus allowance for delays like (getting a glass of water or going to the washroom human needs)

Predetermined time standards

- Predetermined Time Standards are published data that is based on extensive research to determine standard elemental times.
- A common system is the Methods Time Measurement (MTM)
- Analysts are trained and certified before they can be allowed to use MTM.

MTM advantages

- They are based on large number of workers under controlled conditions.
- The analyst is not required to rate performance in developing the standard.
- There is no disruption of the operation.
- Standards can be established even before a job is done.

6.6 Characteristics of Incentive Plan

Operations Manager making use of an Incentive Plan must be able to understand and identify the following characteristics of Incentive Plan.

- Accurate
- Easy to apply
- Consistent
- Easy to understand
- Fair
- Compensation

6.7 Types of Individual Incentive Plans

Pakistani organisations have employed various types of individual incentive plans, which find judicious applications in other countries of the world.

- Group Incentive Plans
- Knowledge-Based Pay System
- Management Compensation of the three mentioned above, the operations manager should be able to identify the advantages and disadvantages of each type of incentive plan.

Summary

- The importance of work design has been often overlooked because the work of Operations Manager in the past was not linked with the Human Resource Department of the same organisation.
- Managers are trained to understand the two basic approaches to job design.
- Study Techniques, which focused on efficiency aspect of the job. This may ignore the behavior aspect but still form an important and integral part of job design.
- Work System Design consists of job design, work measurement and establishment of time standards and worker compensation.
- The interesting fact is that even in decisions in other areas of design can affect the work design system or even a change in the work design system can change the decisions in other areas.
- Like Product or Service, design will affect Design of Work Systems. Layout Decisions will also affect Design of Systems.
- Job design involves specifying the content and methods of job. In general the goal of the job design is to create a work system that is not only productive but also efficient.
- Job designers are concerned with what will be done, who will do the job, how the job will be done.
- Methods analysis deals with analysing how a job gets done, begins with overall analysis and then moves to specific details like changes in tools and equipment, changes in product design or new products, changes in materials or procedures.
- Motion study forms an important part in productivity improvements. It is based on Frank Gilbreths brick laying trade in the early 20th century, with time motion study techniques.
- When we discuss the design part of work systems we often discuss the importance of standard time in work measurement.

Self Assessment

1. _____ are systems in which humans, computer, robotic, and other systems, artifacts and space come together performing activities over time to produce goods, services or, as is the case in the work system described in this paper, scientific discovery.
 - a. Motion system
 - b. Work systems
 - c. Design system
 - d. Service design system

2. _____ is the body of knowledge concerned with analysis of the work methods and the standard of proposed work methods.
 - a. Work design
 - b. Motion study
 - c. Work study
 - d. Method study

3. _____ is the application of techniques designed to establish the time for a qualified worker to carry out a specific job at defined level of performance.
 - a. Work measurement
 - b. Method study
 - c. Work design
 - d. Design system

4. The goal of the _____ is to create a work system that is not only productive but also efficient.
 - a. work design
 - b. motion study
 - c. work measurement
 - d. job design

5. In design of work system, _____ in jobs tends to yield high productivity, low unit costs and lead high standard of living in most of the industrial nations.
 - a. motivation
 - b. specialization
 - c. job rotation
 - d. enrichment

6. Which of the following is used to examine the overall sequence of an operation by focusing on movements of the operator or flow of materials?
 - a. Job design
 - b. Work design
 - c. Flow process chart
 - d. Process design

7. Which of the following is increasing responsibility for planning and coordination tasks, by vertical loading?
 - a. Job Enrichment
 - b. Job Rotation
 - c. Job Enlargement
 - d. Job Design

8. The systematic recording and critical examination of existing and proposed ways of doing work as a means of developing and applying easier and more effective methods and reducing costs.
 - a. Work Study
 - b. Work Design
 - c. Method Study
 - d. Work Measurement

9. Self-directed groups are empowered to make certain benefits in organisation such as higher quality, higher productivity, and greater worker satisfaction are called as _____.
 - a. Teams
 - b. Group dynamics
 - c. Motivated groups
 - d. Self-directed team

10. Match the following.

1. Job enlargement	A. Workers satisfaction
2. Job rotation	B. Increasing responsibility for planning and coordination of tasks
3. Job enrichment	C. Periodically exchange jobs
4. Motivation	D. Giving larger portion of task

- a. 1-A, 2-B, 3-C, 4-D
- b. 1-B, 2-A, 3-D, 4-C
- c. 1-D, 2-C, 3-B, 4-A
- d. 1-D, 2-B, 3-C, 4-A

Chapter VII

Quality Management

Aim

The aim of this chapter is to:

- introduce the concept of quality management in operations management
- explain the terms: ‘quality’ and ‘quality management’
- discuss different types of costs in quality management

Objectives

The objectives of this chapter are to:

- explain the tools of quality control
- elucidate the quality standards in quality management
- explain the total quality management in operations management

Learning outcome

At the end of this chapter, you will be able to:

- identify the reasons for failure of quality management in various fields
- describe the importance of quality standards in management
- understand ‘Total Quality Management’

7.1 Introduction

Successful companies understand the powerful impact customer-defined quality can have on their business. For this reason many competitive firms continually increase their quality standards. For example, both the Ford Motor Company and the Honda Motor Company have recently announced that they are making customer satisfaction their number one priority. The slow economy of 2003 impacted sales in the auto industry. Both firms believe that the way to rebound is through improvements in quality, and each has outlined specific changes to their operations. Ford is focusing on tightening already strict standards in their production process and implementing a quality program called Six-Sigma. Honda, on the other hand, is focused on improving customer-driven product design. Although both firms have been leaders in implementing high quality standards, they believe that customer satisfaction is still what matters most.

7.2 Definition of Total Quality Management

Total Quality Management (TQM) is an integrated effort designed to improve quality performance at every level of the organisation. Customer-defined Quality is defined by the customers is called Customer-defined Quality.

7.2.1 Defining Quality

- Conformance to Specifications
 - ② How well a product or service meets the targets and tolerances determined by its designers.
- Fitness for Use
 - ② It is the quality that evaluates how well the product performs for its intended use.
- Value for Price Paid
 - ② Quality is defined in terms of product or service usefulness for the price paid.
- Support Services
 - ② Quality defined in terms of the support provided after the product or service is purchased.
- Psychological Criteria
 - ② It is the quality that focuses on judgmental evaluations of what constitutes product or service excellence.
- TQM is an integrated organisational effort designed to improve quality at every level.

In this chapter you will learn about the philosophy of TQM, its impact on organisations, and its impact on your life. You will learn that TQM is about meeting quality expectations as defined by the customer; this is called customer-defined quality.

However, defining quality is not as easy as it may seem, because different people have different ideas of what constitutes high quality. Let's begin by looking at different ways in which quality can be defined.

7.3 Cost of Quality

The reason quality has gained such prominence is that organisations have gained an understanding of the high cost of poor quality. Quality affects all aspects of the organisation and has dramatic cost implications.

- The most obvious consequence occurs when poor quality creates unhappy customers and eventually leads to loss of business. However, quality has many other costs, which can be divided into two categories.
- The first category consists of costs necessary for achieving high quality, which are called quality control costs.

These are of two types: Prevention Costs and Appraisal Costs.

The second category consists of the cost consequences of poor quality, which are called Quality Failure costs.

These include External Failure Costs and Internal Failure Costs. These costs of quality are shown in table below.

Prevention Cost	Cost of preparing and implementing Quality
Appraisal Cost	Costs of testing, evaluating, and inspecting quality
Internal failure	Costs of scrap, rework, and material losses.
External failure	Costs of failure at customer site, including returns, repairs, and recalls.

Table 7.1 Cost of quality

The first two costs are incurred in the hope of preventing the second two. Prevention costs are all costs incurred in the process of preventing poor quality from occurring. They include quality planning costs, such as the costs of developing and implementing a quality plan. Also included are the costs of product and process design, from collecting customer information to designing processes that achieve conformance to specifications.

- Employee training in quality measurement is included as part of this cost, as well as the costs of maintaining records of information and data related to quality.
- Appraisal costs are incurred in the process of uncovering defects. They include the cost of quality inspections, product testing, and performing audits to make sure that quality standards are being met.
- Also included in this category are the costs of worker time spent measuring quality and the cost of equipment used for quality appraisal.
- Internal Failure Costs are associated with discovering poor product quality before the product reaches the customer site. One type of internal failure cost is rework, which is the cost of correcting the defective item.
- Sometimes the item is so defective that it cannot be corrected and must be thrown away. This is called scrap, and its costs include all the material, labor, and machine cost spent in producing the defective product.
- Other types of internal failure costs include the cost of machine downtime due to failures in the process and the costs of discounting defective items for salvage value.
- External Failure Costs are associated with quality problems that occur at the customer site.
- These costs can be particularly damaging because customer faith and loyalty can be difficult to regain.
- They include everything from customer complaints, product returns, and repairs, to warranty claims, recalls, and even litigation costs resulting from product liability issues.
- A final component of this cost is lost sales and lost customers. For example, manufacturers of lunch meats and hot dogs whose products have been recalled due to bacterial contamination have had to struggle to regain consumer confidence.

Other examples include auto manufacturers whose products have been recalled due to major malfunctions such as problematic braking systems and airlines that have experienced a crash with many fatalities.

- External failure can sometimes put a company out of business almost overnight.
- Companies that consider quality important invest heavily in prevention and appraisal costs in order to prevent internal and external failure costs.
- The earlier defects are found, the less costly they are to correct. For example, detecting and correcting defects during product design and product production is considerably less expensive than when the defects are found at the customer site as shown in Fig. 7.1

- External Failure Costs tend to be particularly high for service organisations. The reason is that with a service the customer spends much time in the service delivery system, and there are fewer opportunities to correct defects than there are in manufacturing. Examples of external failure in services include an airline that has overbooked flights, long delays in airline service, and lost luggage.

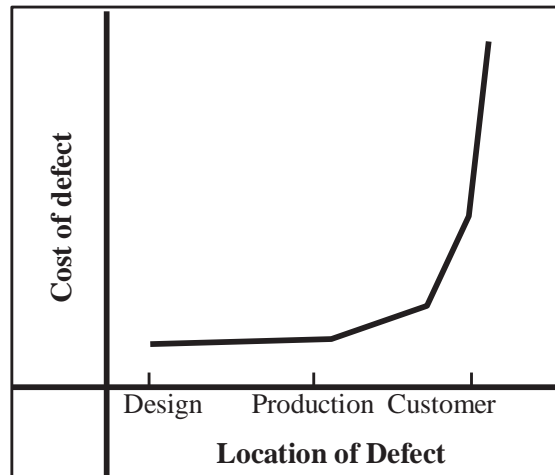

Fig. 7.1 Cost of defects

7.4 Continuous Improvement (Kaizen)

Another concept of the TQM philosophy is the focus on Continuous Improvement. Traditional systems operated on the assumption that once a company achieved a certain level of quality, it was successful and needed no further improvements. We tend to think of improvement in terms of plateaus that are to be achieved, such as passing a certification test or reducing the number of defects to a certain level.

- Traditionally, change for American managers involves large magnitudes, such as major organisational restructuring.
- The Japanese, on the other hand, believe that the best and most lasting changes come from gradual improvements.
- To use an analogy, they believe that it is better to take frequent small doses of medicine than to take one large dose.
- Continuous improvement, called ‘Kaizen’ by the Japanese, requires that the company continually strive to be better through learning and problem solving. Because we can never achieve perfection, we must always evaluate our performance and take measures to improve it.
- Now let’s look at two approaches that can help companies with continuous improvement: the Plan – Do – Study– Act (PDSA) cycle and benchmarking.

Plan to Study Cycle

The Plan Do Study Act (PDSA) cycle describes the activities a company needs to perform in order to incorporate continuous improvement in its operation. This cycle, shown in Figure 5-6 is also referred to as the Shewhart cycle or the Deming wheel. The circular nature of this cycle shows that continuous improvement is a never-ending process.

Let's look at the specific steps in the cycle.

Plan

- The first step in the PDSA cycle is to plan.
- Managers must evaluate the current process and make plans based on any problems they find.
- They need to document all current procedures, collect data, and identify problems.
- This information should then be studied and used to develop a plan for improvement as well as specific measures to evaluate performance.

Do

The next step in the cycle is implementing the plan (do). During the implementation process managers should document all changes made and collect data for evaluation.

Study

The third step is to study the data collected in the previous phase. The data are evaluated to see whether the plan is achieving the goals established in the plan phase.

Act

- The last phase of the cycle is to act based on the results of the first three phases.
- The best way to accomplish this is to communicate the results to other members in the company and then implement the new procedure if it has been successful.

Note that this is a cycle; the next step is to plan again. After we have acted, we need to continue evaluating the process, planning, and repeating the cycle again.

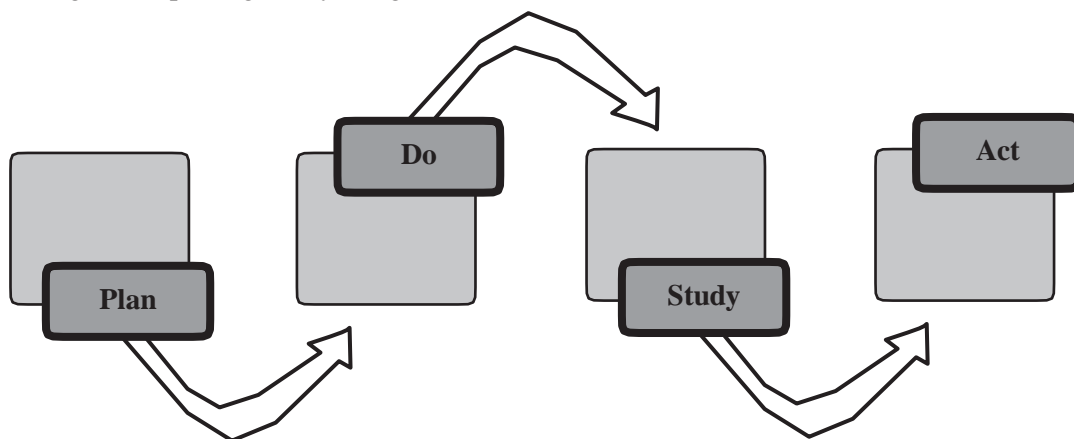

Fig. 7.2 PDSA cycle

Benchmarking

- Another way companies implement continuous improvement is by studying business practices of companies considered “best in class.” This is called as benchmarking.
- The ability to learn and study how others do things is an important part of continuous improvement.
- The benchmark company does not have to be in the same business, as long as it excels at something that the company doing the study wishes to emulate.
- For example, many companies have used Lands’ End to benchmark catalog distribution and order filling, because Lands’ End is considered a leader in this area. Similarly, many companies have used American Express to benchmark conflict resolution.

7.5 Employee Empowerment

Part of the TQM philosophy is to empower all employees to seek out quality problems and correct them. With the old concept of quality, employees were afraid to identify problems for fear that they would be reprimanded. Often poor quality was passed onto someone else, in order to make it “someone else’s problem.”

The new concept of quality, TQM, provides incentives for employees to identify quality problems. Employees are rewarded for uncovering quality problems, not punished.

- In TQM, the role of employees is very different from what it was in traditional systems.
- Workers are empowered to make decisions relative to quality in the production process. They are considered a vital element of the effort to achieve high quality.
- Their contributions are highly valued, and their suggestions are implemented. In order to perform this function, employees are given continual and extensive training in quality measurement tools.
- To further stress the role of employees in quality, TQM differentiates between external and internal customers.
- External customers are those that purchase the company’s goods and services. Internal customers are employees of the organisation who receive goods or services from others in the company.
- For example, the packaging department of an organisation is an internal customer of the assembly department.
- Just as a defective item would not be passed to an external customer, a defective item should not be passed to an internal customer.

7.5.1 Team Approach

TQM stresses that quality is an organisational effort. To facilitate the solving of quality problems, it places great emphasis on teamwork. The use of teams is based on the old adage that “two heads are better than one.”

Using techniques such as brainstorming, discussion, and quality control tools, teams work regularly to correct problems. The contributions of teams are considered vital to the success of the company. For this reason, companies set aside time in the workday for team meetings.

- Teams vary in their degree of structure and formality, and different types of teams solve different types of problems.
- One of the most common types of teams is the quality circle, a team of volunteer production employees and their supervisors whose purpose is to solve quality problems.
- The circle is usually composed of eight to ten members, and decisions are made through group consensus. The teams usually meet weekly during work hours in a place designated for this purpose.
- They follow a preset process for analysing and solving quality problems. Open discussion is promoted, and criticism is not allowed. Although the functioning of quality circles is friendly and casual, it is serious business.
- Quality circles are not mere “gab sessions.” Rather, they do important work for the company and have been very successful in many firms.

7.6 Tools of Quality Control

You can see that TQM places a great deal of responsibility on all workers. If employees are to identify and correct quality problems, they need proper training.

- They need to understand how to assess quality by using a variety of quality control tools, how to interpret findings, and how to correct problems.
- In this section we look at seven different quality tools. These are often called the seven tools of quality control and are shown in Fig.7.3.

- They are easy to understand, yet extremely useful in identifying and analysing quality problems. Sometimes workers use only one tool at a time, but often a combination of tools is most helpful.

Cause-and-Effect Diagrams

Cause-and-effect diagrams are charts that identify potential causes for particular quality problems. They are often called fishbone diagrams because they look like the bones of a fish.

A general cause-and-effect diagram is shown in Figure 7.3. The “head” of the fish is the quality problem, such as damaged zippers on a garment or broken valves on a tire.

- The diagram is drawn so that the “spine” of the fish connects the “head” to the possible cause of the problem. These causes could be related to the machines, workers, measurement, suppliers, materials, and many other aspects of the production process.
- Each of these possible causes can then have smaller “bones” that address specific issues that relate to each cause.
- For example, a problem with machines could be due to a need for adjustment, old equipment, or tooling problems.
- Similarly, a problem with workers could be related to lack of training, poor supervision, or fatigue.
- Cause-and-effect diagrams are problem-solving tools commonly used by quality control teams.
- Specific causes of problems can be explored through brainstorming. The development of a cause-and-effect diagram requires the team to think through all the possible causes of poor quality

Flowcharts

- A flowchart is a schematic diagram of the sequence of steps involved in an operation or process.
- It provides a visual tool that is easy to use and understand. By seeing the steps involved in an operation or process, everyone develops a clear picture of how the operation works and where problems could arise.

Checklists

A checklist is a list of common defects and the number of observed occurrences of these defects. It is a simple yet effective fact-finding tool that allows the worker to collect specific information regarding the defects observed.

- The checklist in Fig.7.3 shows four defects and the number of times they have been observed. It is clear that the biggest problem is ripped material. This means that the plant needs to focus on this specific problem for example, by going to the source of supply or seeing whether the material rips during a particular production process.
- A checklist can also be used to focus on other dimensions, such as location or time. For example, if a defect is being observed frequently, a checklist can be developed that measures the number of occurrences per shift, per machine, or per operator.
- In this fashion we can isolate the location of the particular defect and then focus on correcting the problem.

Control Charts

Control charts are a very important quality control tool. We will study the use of control charts at great length in the next chapter.

These charts are used to evaluate whether a process is operating within expectations relative to some measured value such as weight, width, or volume.

For example, we could measure the weight of a sack of flour, the width of a tire, or the volume of a bottle of soft drink. When the production process is operating within expectations, we say that it is “in control.”

- To evaluate whether or not a process is in control, we regularly measure the variable of interest and plot it on a control chart. The chart has a line down the center representing the average value of the variable we are measuring.
- Above and below the center line are two lines, called the Upper Control Limit (UCL) and the Lower Control Limit (LCL). As long as the observed values fall within the upper and lower control limits, the process is in control and there is no problem with quality. When a measured observation falls outside of these limits, there is a problem.

Scatter Diagrams

- Scatter diagrams are graphs that show how two variables are related to one another. They are particularly useful in detecting the amount of correlation, or the degree of linear relationship, between two variables.
- For example, increased production speed and number of defects could be correlated positively; as production speed increases, so does the number of defects.
- Two variables could also be correlated negatively, so that an increase in one of the variables is associated with a decrease in the other.
- For example, increased worker training might be associated with a decrease in the number of defects observed.
- The greater the degree of correlation the more linear are the observations in the scatter diagram.
- On the other hand, the more scattered the observations in the diagram, the less correlation exists between the variables.
- Of course, other types of relationships can also be observed on a scatter diagram, such as an inverted.
- This may be the case when one is observing the relationship between two variables such as oven temperature and number of defects, since temperatures below and above the ideal could lead to defects.

Pareto Analysis

- Pareto analysis is a technique used to identify quality problems based on their degree of importance.
- The logic behind Pareto analysis is that only a few quality problems are important, whereas many others are not critical. The technique was named after Vilfredo Pareto, a nineteenth-century Italian economist who determined that only a small percentage of people controlled most of the wealth.
- This concept has often been called the 80 – 20 rule and has been extended to many areas.
- In quality management the logic behind Pareto's principle is that most quality problems are a result of only a few causes. The trick is to identify these causes.
- One way to use Pareto analysis is to develop a chart that ranks the causes of poor quality in decreasing order based on the percentage of defects each has caused.
- For example, a tally can be made of the number of defects that result from different causes, such as operator error, defective parts, or inaccurate machine calibrations.
- Percentages of defects can be computed from the tally and placed in a chart like those shown in Fig.7.3. We generally tend to find that a few causes account for most of the defects.

Histograms

- A histogram is a chart that shows the frequency distribution of observed values of a variable.
- We can see from the plot what type of distribution a particular variable displays, such as whether it has a normal distribution and whether the distribution is symmetrical

1. Cause and Effect Diagram

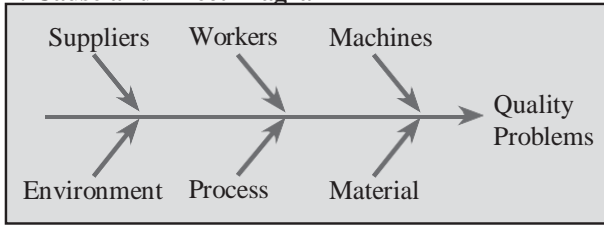

2. Flowchart

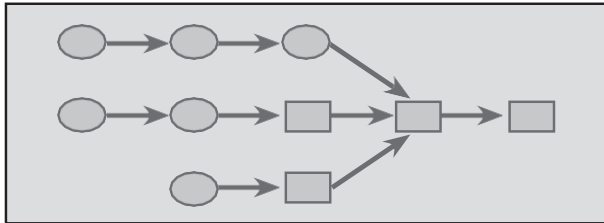

3. Checklist

Detect type	No. of Defects	Total
Broken Zipper	✓✓✓	3
Ripped material	✓✓✓✓✓✓✓	7
Missing buttons	✓✓✓	3
Faded colour	✓✓	2

4. Control Chart

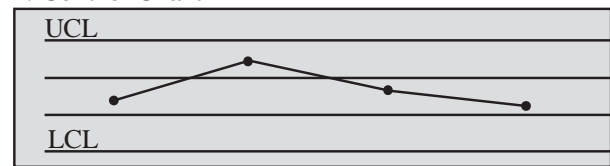

5. Scatter Diagram

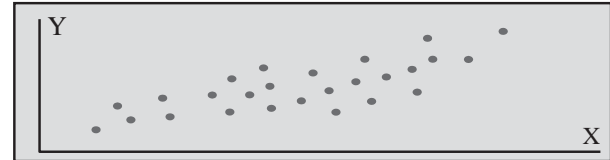

6. Pareto Chart

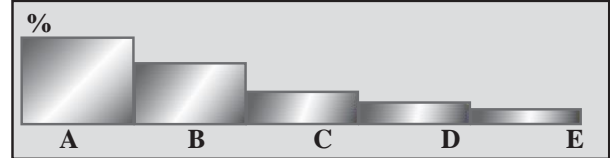

7. Histogram

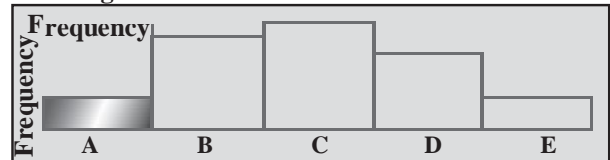

The seven tools of quality control

Fig. 7.3 Seven tools of quality control

7.7 Process Management

- According to TQM a quality product comes from a quality process. This means that quality should be built into the process.
- Quality at the source is the belief that it is far better to uncover the source of quality problems and correct it than to discard defective items after production.
- If the source of the problem is not corrected, the problem will continue. For example, if you are baking cookies you might find that some of the cookies are burned. Simply throwing away the burned cookies will not correct the problem.
- You will continue to have burned cookies and will lose money when you throw them away. It will be far more effective to see where the problem is and correct it. For example, the temperature setting may be too high; the pan may be curved, placing some cookies closer to the heating element; or the oven may not be distributing heat evenly.
- Quality at the source exemplifies the difference between the old and new concepts of quality. The old concept focused on inspecting goods after they were produced or after a particular stage of production.
- If an inspection revealed defects, the defective products were either discarded or sent back for reworking. All this cost the company money, and these costs were passed on to the customer.
- The new concept of quality focuses on identifying quality problems at the source and correcting them.

7.8 Quality Standards

Various quality standards are discussed below.

ISO 9000 Standards

- Increases in international trade during the 1970s created a need for the development of universal standards of quality. Universal standards were seen as necessary in order for companies to be able to objectively document their quality practices around the world.

- Then in 1977 the International Organisation for Standardisation (ISO) published its first set of standards for quality management called ISO 9000.
- The International Organisation for Standardisation (ISO) is an international organisation whose purpose is to establish agreement on international quality standards.
- It currently has members from 91 countries, including the United States. To develop and promote international quality standards, ISO 9000 has been created.
- ISO 9000 consists of a set of standards and a certification process for companies. By receiving ISO 9000 certification, companies demonstrate that they have met the standards specified by the ISO.
- The standards are applicable to all types of companies and have gained global acceptance.
- In many industries ISO certification has become a requirement for doing business. Also, ISO 9000 standards have been adopted by the European Community as a standard for companies doing business in Europe.
- In December 2000 the first major changes to ISO 9000 were made, introducing the following three new standards:
- ISO 9000:2000 Quality Management Systems Fundamentals and Standards: Provides the terminology and definitions used in the standards. It is the starting point for understanding the system of standards.
- ISO 9001:2000 Quality Management Systems Requirements: This is the standard used for the certification of a firm's quality management system. It is used to demonstrate the conformity of quality management systems to meet customer requirements.
- ISO 9004:2000 Quality Management Systems Guidelines for Performance: Provides guidelines for establishing a quality management system. It focuses not only on meeting customer requirements but also on improving performance.

ISO 14000 Standards

- The need for standardisation of quality created an impetus for the development of other standards. In 1996 the International Standards Organisation introduced standards for evaluating a company's environmental responsibility. These standards, termed ISO 14000, focus on three major areas:
- Management systems standards measure systems development and integration of environmental responsibility into the overall business.
- Operations standards include the measurement of consumption of natural resources and energy.
- Environmental systems standards measure emissions, effluents, and other waste systems.

7.9 Reason for TQM Failure

- The most important factor in the success or failure of TQM efforts is the genuineness of the organisation's commitment. Often companies look at TQM as another business change that must be implemented due to market pressure without really changing the values of their organisation.
- Recall that TQM is a complete philosophy that has to be embraced with true belief, not mere lip service. Looking at TQM as a short-term financial investment is a sure recipe for failure.
- Another mistake is the view that the responsibility for quality and elimination of waste lies with employees other than top management. It is a "let the workers do it" mentality.
- A third common mistake is over- or under-reliance on statistical process control (SPC) methods.
- SPC is not a substitute for continuous improvement, teamwork, and a change in the organisation's belief system. However, SPC is a necessary tool for identifying quality problems. Some common causes for TQM failure are;
 - ⓪ Lack of a genuine quality culture
 - ⓪ Lack of top management support and commitment
 - ⓪ Over- and under-reliance on statistical process control (SPC) methods.

- Companies that have attained the benefits of TQM have created a quality culture.
- These companies have developed processes for identifying customer-defined quality.
- In addition, they have a systematic method for listening to their customers, collecting and analysing data pertaining to customer problems, and making changes based on customer feedback.

Summary

- Total quality management (TQM) is different from the old concept of quality because its focus is on serving customers, identifying the causes of quality problems, and building quality into the production process.
- There are four categories of quality costs. The first two are prevention and appraisal costs, which are incurred by a company in attempting to improve quality. The last two costs are internal and external failure costs, which are the costs of quality failures that the company wishes to prevent.
- Seven features of TQM combine to create the TQM philosophy: customer focus, continuous improvement, employee empowerment, use of quality tools, product design, process management, and managing supplier quality.
- Quality function deployment (QFD) is a tool used to translate customer needs into specific engineering requirements. Seven problem-solving tools are used in managing quality. Often called the seven tools of quality control, they are cause-and-effect diagrams, flowcharts, checklists, scatter diagrams, Pareto analysis, control charts, and histograms.
- Reliability is the probability that the product will function as expected. The reliability of a product is computed as the product of the reliabilities of the individual components.
- Companies are evaluated in seven areas, including quality leadership and performance results. These criteria have become a standard for many companies that seek to improve quality.
- ISO 9000 is a certification based on a set of quality standards established by the International Organisation for standardisation. Its goal is to ensure that quality is built into production processes. ISO 9000 focuses mainly on quality of conformance.
- In this chapter we have discussed the meaning of TQM and the great benefits that can be attained through its implementation. Yet there are still many companies that attempt a variety of quality improvement efforts and find that they have not achieved any or most of the expected outcomes.

Self Assessment

1. The category consists of costs necessary for achieving high quality, which are called costs.
 - a. quality control
 - b. prevention
 - c. appraisal
 - d. quality failure

2. _____ includes quality planning costs, such as the costs of developing and implementing a quality plan.
 - a. Appraisal costs
 - b. Internal failure costs
 - c. Prevention costs
 - d. External failure costs

3. The _____ is the first step of Shewart Cycle.
 - a. Plan
 - b. Do
 - c. Study
 - d. Act

4. _____ is an integrated organisational effort designed to improve quality at every level.
 - a. TPM
 - b. TQM
 - c. Kaizen
 - d. Kanban

5. In 1977 the International Organisation for Standardisation (ISO) published its first set of standards for quality management called _____.
 - a. ISO
 - b. ISO 9001
 - c. ISO 9000
 - d. ISO 14000

6. In 1996 the International Standards Organisation introduced standards for evaluating a company's environmental responsibility called as _____.
 - a. ISO
 - b. ISO 9000
 - c. ISO 14000
 - d. ISO 9001

7. Which of the following phases explains the data are evaluated to see whether the plan is achieving the goals established in the plan phase?
 - a. Plan
 - b. Do
 - c. Study
 - d. Act

8. _____ is the sequence of steps involved in an operation or process.
- Checklist
 - Flowchart
 - Control charts
 - Cause and effect diagrams
9. Technique used to identify quality problems based on their degree of importance is known as _____.
- Pareto analysis
 - Statistical process control
 - Histogram
 - Scatter diagrams
10. In which type of diagrams or charts are the upper control limit and the lower control limit reflected?
- Scatter charts
 - Histograms
 - Control charts
 - Statistical Process control

Chapter VIII

Project Planning and Work Breakdown Structure

Aim

The aim of this chapter is to:

- introduce the project planning processes and work breakdown structure
- define project, project management and work breakdown structure (wbs)
- describe project management knowledge areas

Objectives

The objectives of this chapter are to:

- explain project planning and task involved in planning
- emphasise on planning processes
- elucidate the importance of planning and management of processes

Learning outcome

At the end of this chapter, you will be able to:

- identify various problems incurred in the project implementation and its control
- enlist the reasons for failure of project
- understand the importance of Work breakdown structure to take decisions in planning process

8.1 Introduction

A project is temporary endeavour with a finite completion date undertaken to create a unique product or service. Projects bring form or function to ideas and needs.

Examples of project

- Commissioning a new industrial unit
- Construction of house
- Setting up an office
- Developing a technology
- Launching a new product in the market

As we know, that the planning is an important management function without which it is difficult to manage and getting things done. So, in every manufacturing and service industry the various projects are worked out to achieve particular goal of a company, whether it is long term or short term.

8.2 Project Management Knowledge Areas

Project management areas are the following:

- Project integration management, cost management, communication management
- Project scope management, quality management, risk management
- Project time management, human management, procurement management
- Project management knowledge areas describe project management knowledge practices in terms of their component process.

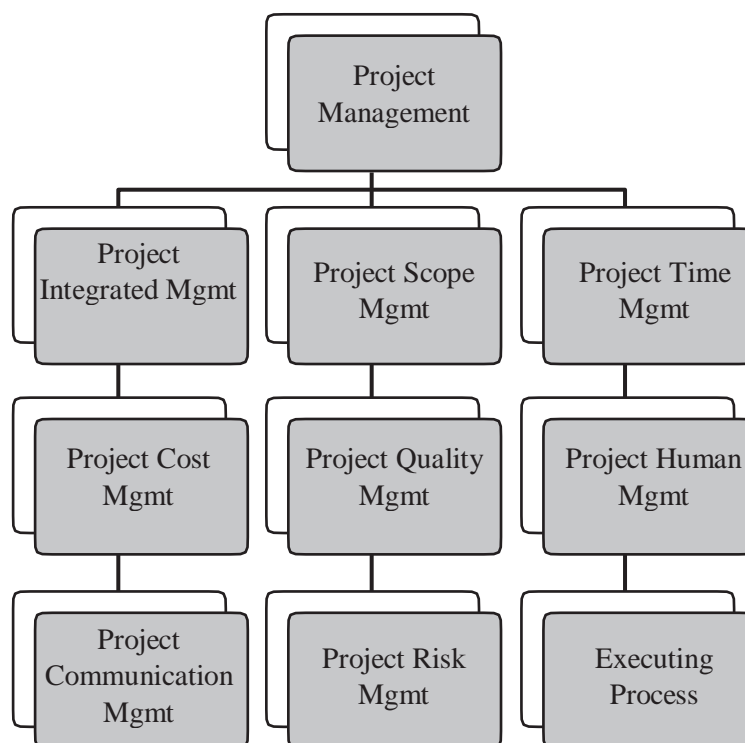

Fig. 8.1 Project management knowledge areas

8.3 Project Failure

A project may fail because of one or more of the following reasons:

Incidence of project failure:

- Project being initiated at random at all levels
- Project objective is not in line with organisation objective
- Lack of observation
- Inexperienced project driver or project manager
- Non-dedicated team
- Lack of complete support from clients

Factors contributing to project success not emphasised:

- Project objective in alignment with business objective
- Working within framework of management methodology
- Proactive approach towards project bottlenecks
- Prior experience of pm in a similar project
- Effective planning scoping, estimation with quality

Overview of Information and Communication Technologies (ICT):

- Involved information and communication technologies like www, email, fibre optics, satellite etc
- Enable societies to produce, access, adapt and apply information in greater amounts more rapidly and at reduced costs offer enormous opportunities for enhancing business and economic viability

Common problems encountered during projects:

- No prioritisation of project activity from an organisational positions
- One or more of the stages in the project mishandled
- Less qualified and non dedicated manpower
- Absence of smooth flow of communication between the involved parties

8.4 Project Planning

Project planning is the systematic arrangement of activities within particular framework of project and on the desired parameters with expected result.

Scoping

The main objectives of scoping are:

- Define the project boundaries
- Explicitly stating objectives what the project will cover
- Implicitly providing direction to the project and enabling assessment of the final products quality

Scoping of project will enable PM to prepare an outline of the project plan;

For any project work to be undertaken, it is good practice to prepare an outline of the project. The outline comprises following points:

- Describe the relevant context for the project
- Indicating purpose and objective of project
- Making list of all task pertaining project along with target time

A Typical Outline of the Task

- Development of plan and approval of the plans
- Literature survey
- Data collection
- Data analysis
- Findings
- Interpretation and conclusions
- Recommendation on the project and presentation
- Documentation of report
- Use of gantt-chart of tasks to monitor and control project deliverables
- Identify strengths and weaknesses of project

Tasks Involved in Scoping

Following are the tasks involved in scoping

- Establish project objectives which could be identified from clients through workshops and interviews. This will ensure project alignment with the business direction of the organisation. Project objectives may be formulated as S.M.A.R.T.
S – Specific
M – Measurable
A – Achievable
R – Relevant
T – Time terminated
- Establish scope of investigation in order to determine the dimension that apply to project and identify constraints.
- Identify initial requirement and validate them against the project objectives.
- Identify the criteria for assessing the success of both the final project product and process used to create it.
- Identify outline solution to illustrate the feasibility of achieving the defined business requirement for the project.
- Identify training requirement to determine the probable client training and technical writing.
- Review project scope by first reviewing the objectives, statement and scope definition documents and then verify whether it has met the standards.

8.5 Project Plan

The project plan is preliminary document that guides the execution of a project. The key stages work plans and the actual performance should be compared with the project plan prepared for a particular stage.

The plan should be tracked throughout for which various checklists could be used. The value of certain parameters must be measured.

8.5.1 Planning Tools

Following are the planning tools

Project organisation and structure

Identify the personnel. Identify those business areas that are within scope or directly interface with the scope boundary and list them in the business area column of the project assignment sheet.

Project management team

- identify senior management team
- manage the project on daily basis
- project coordinators must be assigned
- clearly define these coordination and control activities and identify

Key stakeholders

- identify management level personnel who are official to the success
- document the responsibilities of stakeholders

Stage teams

- identify appropriate personnel required for the stage, define the team structure and appoint team leaders
- document the time commitment and responsibilities to be performed by the team members

Key resources

- Individuals assigned to a key resources role may work towards gathering “Business Key Resources and “Technical Key Resources”

Determining training requirements

- Assess the capabilities and skills of all those identified as part of the project organisation based upon this assessment establish a training plan to acquaint the project team members with the methodologies, technologies and business areas under study
- Update the project schedule to incorporate schedule training activities

8.6 Project Process Flow

Project planning is composed of interacting processes organised in following groups

Project Process

A project process is a series of activities to achieve the target. Project processes is classified into two main categories:

- Project management process: It is defined by the organisation. it describes and organises the work of the project.
- Project oriented process: It is defined by the life cycle, it specifies and creates products and related works.

Process Groups

It consists of following:

- Initial processes: Recognition to start and establishing commitment
- Planning processes: Devising and maintaining a workable scheme to accomplish the business need
- Executing processes: Coordinating people to carry out the plan
- Controlling process: Monitoring and measuring progress and taking remedial action
- Closing processes: Formalising acceptance and ending project

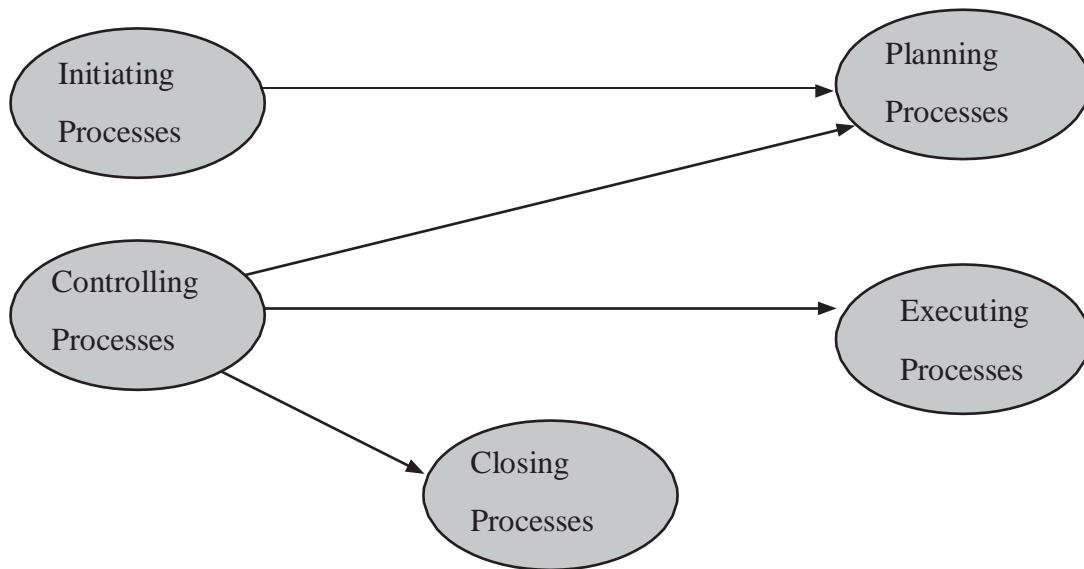

Fig. 8.2 Connection between process groups in a phase

Planning processes

- It has major importance
- These are highly interdependent

Executing processes

- It depends on the nature of the work
- They are dynamic and dependent on team innovation

Controlling processes

- It includes, Measuring project performance
- Identifying variances from the plan
- Updating project plans
- Taking corrective action

Closing processes

- Review of the project
- Findings
- Analysis of the project performance with respect to various processes

Process interactions

- The individual process are linked by inputs and outputs
- Inputs: it refers to the client documents converted to action plans to be acted upon
- Tools and techniques: it refers to the mechanism applied on to the inputs created by desired outputs
- Outputs: it refers to the documents that are results of the process

Customisation

- Large project may need details.
- Smaller project may need relatively less details
- Resource identification might be required for scope definition.

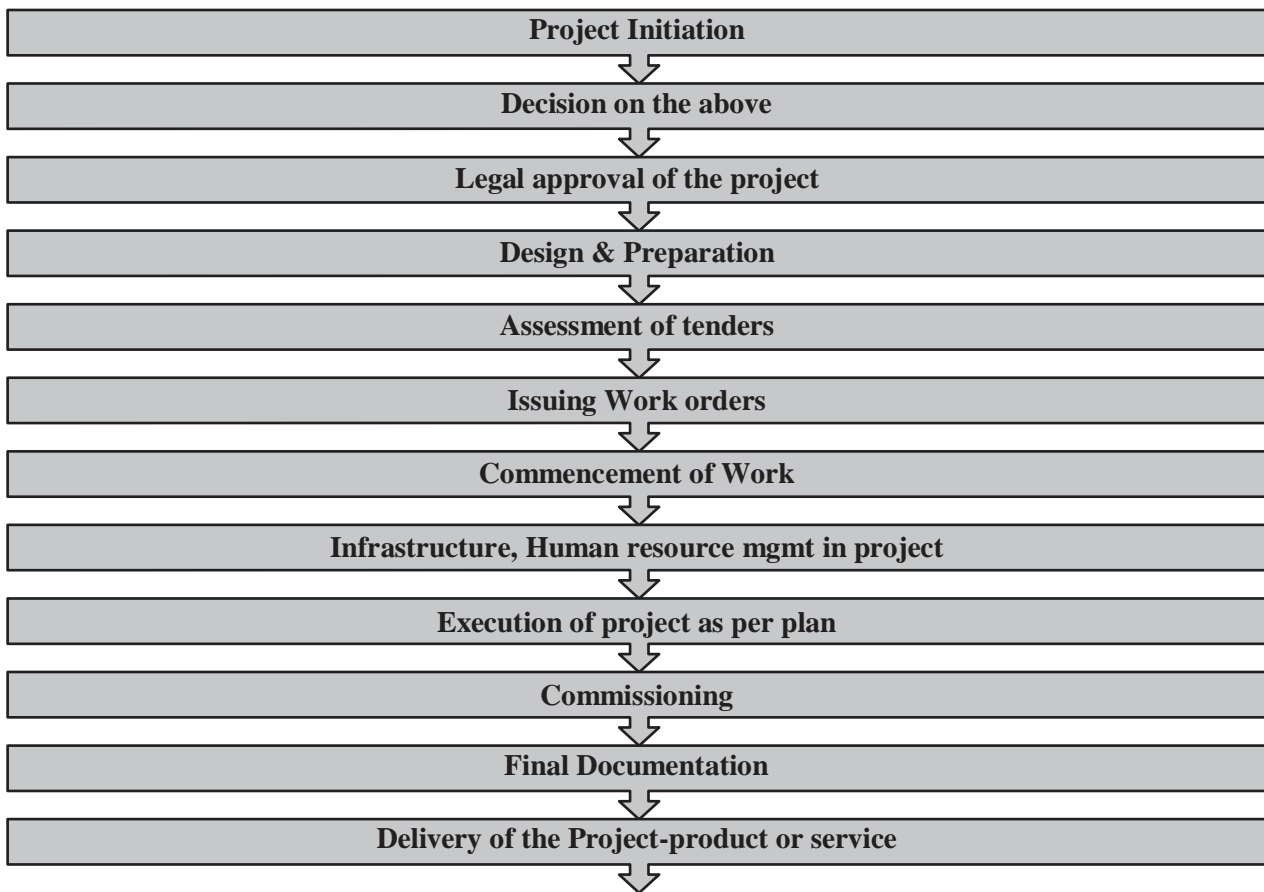

Fig. 8.3 Schematic flow diagram of the processes

8.7 Work Breakdown Structure (WBS)

WBS is technique to analyse the content of work and cost by breaking it down into its component parts:

- Project key stages from the highest level of the WBS, which is then used to show the detail at the lower levels of the project.
- Each key stage comprises many tasks identified at the start of planning and later this list has to be validated.
- WBS is produced by identifying the key elements, breaking each element down into component parts and continuing to breakdown until manageable work packages have been identified. These can be allocated to the appropriate person.
- The WBS does not show dependencies other than a grouping under the key stages.
- Identifying lead and lag times help in working out task duration.
 - ⦿ Lead Time: An amount of time which a successor task can overlap with its predecessor, i.e., the time before the completion of the predecessor at which the successor can start.
 - ⦿ Lag Time: An amount of time between a predecessor and a successor task, i.e. the time after completion of the predecessor that the start of the successor is delayed.

Summary

- A project is a temporary endeavour with a finite completion date undertaken to create a unique product or service.
- Projects bring form or function to ideas or needs.
- A good project management methodology provides a framework for the processes
- Project key stages from the highest level of the WBS, which is then used to show the detail at the lower levels of the project.
- Each key stage comprises many tasks identified at the start of planning and later this list has to be validated.
- WBS is produced by identifying the key elements, breaking each element down into component parts and continuing to breakdown until manageable work packages have been identified. These can be allocated to the appropriate person.

Self Assessment

1. A project is temporary venture to create a unique_____.
 - a. Product
 - b. Service
 - c. Idea
 - d. Product or Service

2. Project integration management, cost management, communication management, Project scope management, quality management, risk management, Project time management, human management, procurement management are_____.
 - a. PM Knowledge Areas
 - b. PM Knowledge Forms
 - c. PM Knowledge Links
 - d. PM Knowledge Outputs

3. If Project objective is not in line with_____objective then Project fails.
 - a. production
 - b. suppliers
 - c. organisation
 - d. customer

4. The systematic arrangement of activities within particular framework of project and on the desired parameters with expected result, is called_____.
 - a. project management
 - b. project scheduling
 - c. project planning
 - d. project scheming

5. _____ is preliminary document that guides the execution of a project.
 - a. Project chart
 - b. Project plan
 - c. Project notification
 - d. Project disclaimer

6. These are the series of activities to achieve the target are called as_____.
 - a. project processes
 - b. process groups
 - c. process interaction
 - d. customisation

7. In process groups,_____deals with monitoring and measuring progress and taking remedial action.
 - a. planning process
 - b. executing process
 - c. controlling process
 - d. closing process

8. _____ deals with Devising and maintaining a workable scheme to accomplish the business need.
- Planning processes
 - Executing processes
 - Controlling process
 - Closing processes
9. In Process interaction, the mechanism applied on to the inputs created by desired outputs is known as _____.
- inputs
 - tools and techniques
 - outputs
 - transformation
10. Which of the following is the technique to analyse the content of work and cost by breaking it down into its component parts?
- Project scoping
 - Work breakdown structure
 - Process interaction
 - Customisation

Chapter IX

JIT, Lean Manufacturing, Six-Sigma

Aim

The aim of this chapter is to:

- understand the concept of Just-In-Time
- explain the lean manufacturing system
- introduce six sigma

Objectives

The objectives of this chapter are to:

- define JIT, lean manufacturing and six sigma in production system
- discuss the principles of JIT, lean manufacturing and six sigma
- emphasise on lean production system to improve manufacturing and service operations

Learning outcome

At the end of this chapter, you will be able to:

- understand the difference between quality management tools
- identify the importance of JIT, lean manufacturing in operations management
- recognise the benefits and major pitfalls of existing manufacturing system

9.1 Introduction

The primary goal for the company is customer's satisfaction and if company cannot reach perfection in this area then all the processes are worthless.

- All parts of the value chain and everything in the enterprise must be healthy for realisation of competitive business processes.
- If the company wants strong and long lasting value chain all the links within the chain must be prepared to overpass all existing problems.
- One of the most important links inside that value chain is definitely logistics. Logistics is concerned with the physical distribution and storage of products and services.
- During the 20th century several approaches of implementation of logistics were developed. Surely, one the most famous and most important logistics concept is the Just-In-Time concept.

9.2 History and Philosophy of Just-In-Time (JIT)

- Problems before JIT system were that companies cannot properly calculate their material flows.
- Also, there were problems with warehouses because there were situations that in one moment warehouses are full with stocks, and in other they are almost empty.
- Because of these problems it was really difficult for engineers and managers to deal with logistics.
- JIT, however, is not new.
- The technique was first used by the Ford Motor Company during 1920s, but the technique was subsequently adopted and publicised by Toyota Motor Corporation of Japan as part of its Toyota production System (TPS).
- In 1954 Japanese giant Toyota implemented this concept in order to reduce wasteful overstocking in car production.
- Just-in-time (JIT) inventory systems are not just a simple method that a company has to buy in to; it has a whole philosophy that the company must follow.
- The ideas in this philosophy come from many different disciplines including; statistics, industrial engineering, production management and behavioral science.
- In the JIT inventory philosophy there are views with respect to how inventory is looked upon, what it says about the management within the company, and the main principle behind JIT.
- Firstly, inventory is seen as incurring costs instead of adding value, contrary to traditional thinking. Under the philosophy, businesses are encouraged to eliminate.

9.3 Just-In-Time Concept

Since the emergence of this term it was difficult for sciences and business people to define it. Even today many companies think that they are using JIT concept, but actually, they are not realising that JIT must be integrated in company philosophy and no just dead letters.

- Just in Time (JIT) production is a manufacturing philosophy, which eliminates waste associated with time, labour, and storage space.
- Basics of the concept are that the company produces only what is needed, when it is needed and in the quantity that is needed.
- The company produces only what the customer requests, to actual orders, not to forecast. JIT can also be defined as producing the necessary units, with the required quality, in the necessary quantities, at the last safe moment.
- It means that company can manage with their own resources and allocate them very easily.

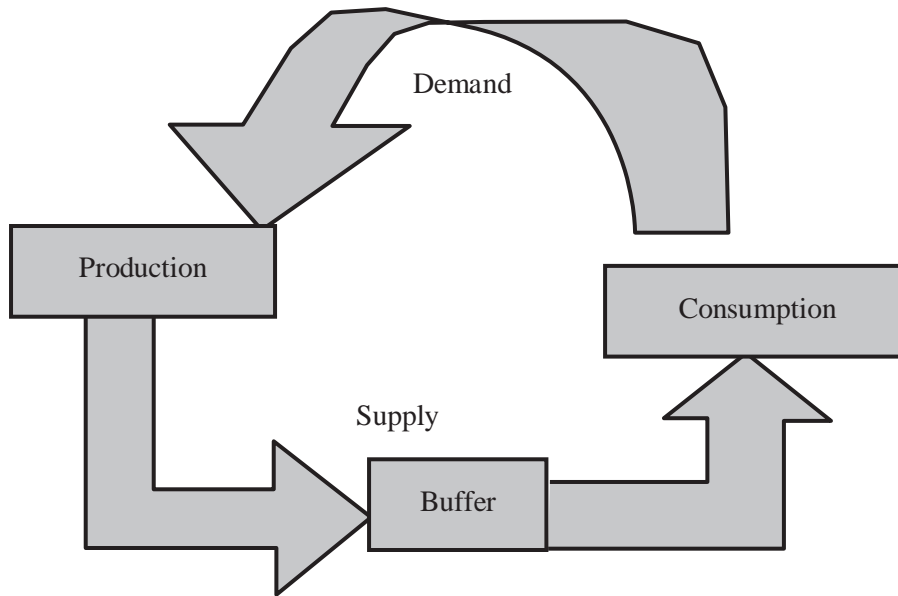

Fig. 9.1 Drawing of the JIT concept

9.4 Benefits and Problems

Benefits that JIT concept can provide to the company are huge and very diverse. The main benefits of JIT are listed below:

- Reduced set up times in warehouse - the company in this case can focus on other processes that might need improvement;
- Improved flows of goods in/through/out warehouse employees will be able to process goods faster;
- Employees who possess multi-skills are utilised more efficiently the company can use workers in situations when they are needed, when there is a shortage of workers and a high demand for a particular product;
- Better consistency of scheduling and consistency of employee work hours if there is no demand for a product at the time, workers don't have to be working. This can save the company money by not having to pay workers for a job not completed or could have them focus on other jobs around the warehouse that would not necessarily be done on a normal day;
- Increased emphasis on supplier relationships - having a trusting supplier relationship is important for the company because it is possible to rely on goods being there when they are needed;
- Supplies continue around the clock keeping workers productive and businesses focused on turnover – employees will work hard to meet the company goals.
- Also, the benefits of JIT include: better quality products, higher productivity and lower production costs. For better understanding of JIT benefits, Table 9.1 shows comparing between flexible systems (based on Just-In-Time systems) and buffered/rigid systems.
- It is certain that JIT concept can improve business performance and efficiency. Employee morale is likely increased and that is one most important benefit that comes from using the foregoing concept. Of course, we must not forget that now the company is allowed to remain competitive.

	Lean Flexible System (Just-In-Time System)	Buffered/Rigid System (Just-In-Case system)
Production System	Customer orders pulls product through the factory	The system pushes the product through the factory
Production Lot Size	Small batches are made with reduced setup time	Large batches are made due to high setup time
Process Design	Concurrent engineering design is applied	Process designed after product has been designed
Inventory Turnover	High turnover with minimum inventory level	Low turnover due to high inventory level
Suppliers	Fewer number and they are helped informed and kept close	Suppliers are kept at arms length
Employees	Multi skilled, flexible and work well in teams	Specialised and with strict work rules
Decision-making	Empowerment of workers enables quick response	Centralised at management level
Quality	Everyone's responsibility	Q.C. inspectors job
System Improvement	Emphasis is on small but continuous improvement	"If it isn't broke, dont fix it" attitude.

Table 9.1 Comparison between flexible systems and buffered/rigid systems

There are several problems, which are connected within JIT concept.

- The major problem with JIT operation is that it leaves the supplier and downstream consumers open to supply shocks.
- With shipments coming in sometimes several times per day, the company is especially susceptible to an interruption in the flow. For that reason, some companies are careful to use two or more suppliers for most of their assemblies.
- The hidden costs are present and they include labour union leverage, problems with flexible manufacturing systems (FMS), problems developing for the flexible workforce, difficulties with supplying commodities using
- JIT, increased expenses for suppliers.

9.5 Implementation of JIT

- How a company will implement the JIT concept depends on many factors. For example, if a company has more than 100.000 workers and production in different places, then the implementation of JIT needs to be done in interaction with all departments. It is obvious that for large companies more time will be spent.
- On the other hand, smaller companies have the opportunity to implement the JIT concept much faster because their organisation structure is not so complicated. But it does not mean that smaller companies are better in JIT implementation.

There are several general guideline steps for easier JIT implementation. The following algorithm shows what the company has to do if it wants to implement the JIT concept.

1. Top management must accept idea of the JIT.

Without their permission it is not possible to move on with the whole process. They are responsible for ensuring financial resources for the project. Perhaps the most difficult thing for engineers is to convince managers that the company under consideration really needs implementation of the JIT concept in order to improve business processes.

Convincing managers to allow evaluation of JIT is not only a problem that comes from human.

2. Second step for a company is success which is connected with the fact that employees also have to understand significance of the new concept.

Very important in this step is to explain to workers that JIT is not some kind of bad monster and not something unimportant for their work. It is desirable to hold a series of training sessions to familiarise employees with the fundamentals of the JIT concept.

When we succeed once to explain to our human resources the importance of the new concept and if they become cognizant about it, now it is possible to continue.

3. The third step would be the setup of ERP (Enterprise Resource Planning).

ERP is a system which integrates all data and processes of an organisation into a single unified system.

It is impossible nowadays to run successful production without strong support of an information system.

So, it means that ERP requests the software and hardware systems with a secure and huge data base which is able to collect all information about resources.

With a centralised data base it is much easier to manage all enterprise resources. It is especially important for logistics because, as we mentioned before, logistics can be considered as a tool for getting resources, like products, services, and people, where they are needed and when they are desired.

If the ERP system is well established, the next step would be to test our own system.

Now all preconditions of the JIT implementation are considered and we are trying to figure out: are there any difficulties to start with implementation. In this step one question comes up: "Is the system ready for JIT implementation?".

When the answer is NO, it is recommendable to go back and do changes. If the answer is YES, everything is prepared for the implementation process.

Apropos the technical and physical parts of the implementation, maybe the most important thing which is worth of mentioning is that during the process the organisation must not rush.

4. The last step is testing and control. For successful existence and developing of the JIT system there must be continuous control. Without control things can sway from the right direction. Of course, feedback loops also exist and they are very important for the whole process.

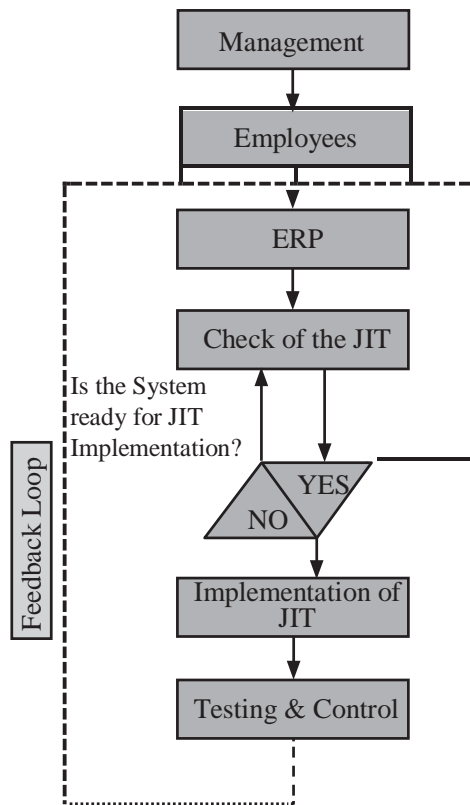

Fig. 9.2 Algorithm of JIT implementation

9.6 Lean Manufacturing

Following are the concepts in lean manufacturing

Lean Production

- Lean is about doing more with less. (less time, inventory, space, labor, money)
- Lean manufacturing a shorthand commitment to eliminating waste, simplifying procedures and speeding up production
- Lean manufacturing is also known as Toyota Production System (TPS).
- The systematic elimination of wastes like, overproduction, waiting, transportation, inventory, motion, over processing, defective units and the implementation of the concepts of continuous flow and customer pull.

The five areas of Lean manufacturing or production are:

- cost
- quality
- delivery
- safety and
- morale

Just as a mass production is recognised as the production system of the 20th century lean production is viewed as the production system of the 21st century.

Lean Production Overview

- Non-value added activities or waste are eliminated through continuous improvement efforts.
- Focus on continuous improvement of processes – rather than results - of the entire value chain.
- The lean manufacturing mindset: concept, way of thinking – not techniques; culture – not the latest management tool.
- Continuous product flow is achieved through physical rearrangement and system structure and control mechanisms.
- Single-piece flow / small lot production: achieved through equipment set up time reduction; attention to machine maintenance; and orderly, clean work place.
- Pull reduction / Just-in-Time inventory control.

Basic Elements of Lean Manufacturing

- The basic elements are waste elimination, continuous one piece workflow, and customer pull.
- When these elements are focused in the areas of cost, quality and delivery, this forms the basis for a lean production system.
- The lean production concept was to a large extent inspired by the Kaizen the Japanese strategy of continuous improvement.
- Employee empowerment and promotion among them of a way of thinking oriented at improving processes, imitation of customer relationships, fast product development and manufacturing, and collaboration with suppliers are the key strategies of leading lean companies.

Characteristics of a Lean Enterprise

Following are the characteristics of a lean enterprise

- Integrated single piece continuous workflow.
- Close integration of the whole value chain from raw material to finished product through partnership oriented relations with suppliers and distributors.
- Just-in-time processing: a part moves to a production operation, is processed immediately, and moves immediately to the next operation.
- Short order-to-ship cycles times; small batch production capability that is synchronised to shipping schedules. Production is based on orders rather than forecasts; production planning is driven by customer demand or “pull” and not to suit machine loading or inflexible work flows on the shop floor.
- Minimal inventories at each stage of the production process.
- Quick changeovers of machines and equipment allow different products to be produced with one-piece flow in small batches.
- Layout is based on product flow.
- Total quality control: Active involvement by workers in trouble shooting and problem solving to improve quality and eliminate wastes.
- Defect prevention rather than inspection and rework by building quality in the process and implementing real time quality feedback procedures.
- Team-based work organisations with multi skilled operators empowered to make decisions and improve operations with few indirect staff.

9.7 Key Feature of Lean Production

Following are the characteristics of a lean enterprise

- Reduced Setup Cost and Times (for semi-versatile machinery such as big stamping presses) – from months to hours thus making small-lot production economically viable; achieved by organising procedures, using carts, and training workers to do their own setups,
- Small-Lot Production – allowing higher flexibility and pull production (or just-in-time manufacturing)
- Employee Involvement and Empowerment – organising workers by forming teams and giving them training and responsibility to do many specialised tasks, for housekeeping, quality inspection, minor equipment repair and rework; allowing also them time to meet to discuss problems and find ways to improve the process
- Quality at the Source – total quality management (TQM) and control; assigning workers, not inspectors, the responsibility to discover a defect and to immediately fix it; if the defect cannot be readily fixed, any worker can halt the entire line by pulling a cord (called jidoka)
- Pull Production, or Just-In-Time (JIT) – the method wherein the quantity of work performed at each stage of the process is dictated solely by the demand for materials from the immediate next stage; thus reducing waste and lead times, and eliminating inventory holding costs
- Continuous Equipment Maintenance – as pull production reduces inventories, equipment breakdowns must also be reduced; thus empowered operators are assigned primary responsibility for basic maintenance since they are in the best position to detect signs of malfunction
- Multi- Skilled Workforce – as employees are empowered to do many jobs, they must be provided with adequate training
- Supplier Involvement – the manufacturer treats its supplier as a long-term partners; they often must be trained in ways to reduce setup times, inventories, defects, machine breakdowns, etc. in order to enable them to take responsibility for delivering the best possible parts/services to the manufacturer in a timely manner.

9.8 Benefits of Lean Production

Establishment and mastering of a lean production system would allow you to achieve the following benefits:

- Waste reduction by 80%
- Production cost reduction by 50%
- Manufacturing cycle times decreased by 50%
- Labor reduction by 50% while maintaining or increasing throughput
- Inventory reduction by 80% while increasing customer service levels
- Capacity in current facilities increase by 50%
- Higher quality
- Higher profits
- Higher system flexibility in reacting to changes in requirements improved
- More strategic focus
- Improved cash flow through increasing shipping and billing frequencies

However, by continually focusing on waste reduction, there are truly no end to the benefits that can be achieved.

9.9 Five Elements to Enabling Approach

- Specify Value: Value is defined by the ultimate customer's needs through tools such as value management, quality function deployment and simulation.
- Identify and Map the Value Stream: The value stream identifies all those steps required to make a product. Identifying value stream, the way value is realised, establishes when and how decisions are to be made. The key technique behind value stream is process mapping for a very specific reason: that of understanding how value is built into the building product from client's point of view.

- Flows: Flows are characterised by time, cost and value. Resources (labor, material and construction equipment) and information flows are the basic units of analysis.
- Pull: At a strategic level, pull identifies the real need to deliver the product to the customer as soon as he needs it.
- Perfection: To achieve perfection means constantly considering what is being done; how it is being done and harnessing the expertise and knowledge of all those involved in the processes to improve and change it. With continuous improvement done and with waste eliminated along the flow process, perfection is the ultimate sweet reward that companies can achieve.

9.10 13 Tips to Transition Company into Lean Enterprise

- Begin with action in the technical system and then follow quickly with cultural change.
- Learn by doing first and training second.
- Start with value stream pilots to demonstrate lean as a system and provide a “go see model”.
- Use value stream mapping to develop future state visions and help “learn to see”.
- Use Kaizen workshops to teach and make rapid changes.
- Organise over value streams.
- Make it mandatory.
- A crisis may prompt a lean movement, but may not be necessary to turn the company around.
- Be opportunistic in identifying opportunities for big financial impacts.
- Realign metrics with value streams perspective.
- Build on your company’s roots to develop your own way.
- Hire or develop lean leaders and develop a succession system.
- Use experts for teaching and getting quick results.

9.11 Six-Sigma

Six-Sigma is a long-term, forward-thinking initiative designed to fundamentally change the way corporations do business. It is first and foremost “a business process that enables companies to increase profits dramatically by streamlining operations, improving quality, and eliminating defects or mistakes in everything a company does.

While traditional quality programs have focused on detecting and correcting defects, Six Sigma encompasses something broader: It provides specific methods to re-create the process itself so that defects are never produced in the first place.”

Objectives of Six-Sigma

Following are the objectives of six-sigma

- To satisfy the customer
- To lift internal performance
- To enable better performance by better design
- To improve the quality of purchased supplies
- To reduce the costs

Integrating Six Sigma with Business Process Management

Six-Sigma is frequently implemented in a traditional departmental paradigm without much reliance on business process thinking.

- It is little wonder that many thoughtful Six Sigma practitioners complain of the difficulty in identifying the best opportunities to apply Six Sigma techniques, and of the fact that there are frequently overlapping and redundant Six Sigma projects.

- The practice of piecemeal thinking with respect to various improvement initiatives is a serious issue and the failure of integrating business process thinking with Six Sigma methods, results in firms incurring such significant opportunity costs that it is downright tragic.
- Integrating Six Sigma with business process management principles will help you realise significant opportunities versus the traditional methods of implementing a Six Sigma program.

Just consider the few examples cited below.

- By asking and answering the question ‘Which business process would have to be improved by how much, by when, in order for us to realise our strategic objectives your firm would have greater clarity on where to apply Six Sigma techniques and for what results.
- By structuring, the entire improvement initiative according to business processes there would be fewer overlapping initiatives and more cross-departmental collaboration.
- Since process ownership relies on managing by influence as opposed to authority, process owners would collaboratively sponsor projects and project progress would be monitored by a ‘Steering Team’ of executives thereby reducing the frequency of project collapse which sometimes observed when Six Sigma is deployed on a traditional basis due to tribal warfare.
- Because of the big picture view, leadership could decide, based on the size of the performance gap that needs to be bridged and the firm’s appetite/capability to absorb change, when to deploy DFSS (design for six sigma) methodology – or better yet, process redesign techniques – as opposed to the traditional DMAIC (define, measure, analyse, improve, control).
- The application of business process thinking in conjunction with Six Sigma would inject greater sensitivity to the human side of change and help address one of the pervasive criticisms of the Six Sigma in that it is less effective in solving historically “soft” issues.

On the other hand, process improvement methods would benefit from the rigor of Six Sigma measurement techniques and its disciplined training regime.

Six Main Benefits of the Sigma Breakthrough Strategy

Following are the benefits of Sigma Breakthrough Strategy Remarkable improvements i

- Processes
- Products and services
- Investor relations
- Design methodology
- Supplier relationships
- Training and recruitment

Difference between TQM and Six Sigma

Total Quality Management (TQM) programs focus on improvement in individual operations with unrelated processes; as a consequence, it takes many years before all operations within a given process are improved.

Six Sigma focuses on making improvements in all operations within a process, producing results more rapidly and effectively

Critical Success Factors of an Organisation

For Successful TPS-Lean Six Sigma Implementation

- Active commitment and involvement from Senior Executives
- Improvement goals integrated into the OBSC and Project BSC
- Deployment of the communications plan

- Project selection, prioritisation, tracking and reviewing process
- Extensive education and training
- An atmosphere of trust, commitment, teamwork, creativity, and learning within project teams
- Sustainable project results
- Technical support and training (Master Black Belts, Black Belts, Green Belts)
- Full-time vs. part-time resources
- Human resource management and Human Capital embedded in the project
- Alignment of personal ambition of project members and project ambition (Project BSC)
- Alignment of personal ambition of employees and shared organisational ambition (OBSC)
- Project BSC is related to the OBSC and Personal BSC
- Incentives, recognition, reward and celebration
- Supplier involvement Management accountability for quality improvement

Summary

- If the company wants to have a JIT concept it does not mean that everything must be done very fast. The most important thing for the company is to have good organised resource allocation.
- Also, the management and employees must have on their mind that this concept can help the organisation to solve many problems in logistics.
- It is true that implementation and development of JIT is a long-lasting and expensive process, but if the company can manage with these difficulties it is possible to achieve high levels of workflow.
- The JIT concept is only one part in the value chain that brings the satisfaction to the customers. It means that the JIT concept cannot solve existing problems in other organisation processes.
- Everything in enterprises is needed to be healthy, through the hierarchy of employees and all workflow processes. Synergy is the only thing that can improve business results. And in the bottom line, the JIT concept is just one link in the whole chain, but very important.
- Reduced set up times in warehouse - the company in this case can focus on other processes that might need improvement.
- Improved flows of goods in/through/out warehouse employees will be able to process goods faster.
- Employees who possess multi-skills are utilised more efficiently the company can use workers in situations when they are needed, when there is a shortage of workers and a high demand for a particular product.
- Better consistency of scheduling and consistency of employee work hours if there is no demand for a product at the time, workers don't have to be working. This can save the company money by not having to pay workers for a job not completed or could have them focus on other jobs around the
- Warehouse that would not necessarily be done on a normal day;
- Increased emphasis on supplier relationships - having a trusting supplier relationship is important for the company because it is possible to rely on goods being there when they are needed;
- Supplies continue around the clock keeping workers productive and businesses focused on turnover – employees will work hard to meet the company goals.
- Lean is about doing more with less. (Less time, inventory, space, labour, money)
- Lean manufacturing a shorthand commitment to eliminating waste, simplifying procedures and speeding up production
- The five areas of Lean manufacturing or production are: Cost, Quality, Delivery, Safety and Morale.
- Five Elements to Enabling Approach ARE: Specify value, Identify and map the value stream, Flows, Pull and Perfection





